

Terminator™ ZT-R-WP Terminator™ ZT-C-R-WP Thermostat Connection Kit INSTALLATION PROCEDURES



For Thermostat Connection (1-2 Heating Cables) Applications
For Use With TESH Series Constant Watt Heating Cables



Terminator™ ZT-(C)-R-WP INSTALLATION PROCEDURES

The following installation procedures are guidelines for the installation of the Terminator ZT-R-WP & ZT-C-R-WP Kits.

Kit Contents . . .



Item	Quantity	Description						
1	1	Expediter Assembly Support Cap with O-Ring Threaded Grommet Compressor Grommet Support Base with O-Ring						
2	1	Junction Box Lid						
3	1	Junction Box Base with O-Ring & M25 Dust Cap						
4	1	Nut						
5	1	Banding						
6	1	Thermostat w/ Terminal Blocks (Refer to terminal specifications for maximum allowable wire size)						
		<table border="0"> <tr> <td><u>Thermostat Type</u></td> <td><u>Terminals</u></td> </tr> <tr> <td>ZT-C-230 Vac</td> <td>4 mm² terminals</td> </tr> <tr> <td>ZT-C-400 Vac</td> <td>6 mm² terminals</td> </tr> </table>	<u>Thermostat Type</u>	<u>Terminals</u>	ZT-C-230 Vac	4 mm ² terminals	ZT-C-400 Vac	6 mm ² terminals
<u>Thermostat Type</u>	<u>Terminals</u>							
ZT-C-230 Vac	4 mm ² terminals							
ZT-C-400 Vac	6 mm ² terminals							
7	1	Capillary Armouring w/ Glands						
8	1	Junction Box Cord						
9	1	Blind Plug						
10	1	Bracket						
11	3	Screws						
12	3	Washers						

Order Separately . . .

Cold Lead Connection

PETK-10 for cold lead connection (TESH 2.9-15)

PETK-11 for cold lead connection (TESH 17.8-8000)

IEK Insulation Entry Kit (per cable)

IEK-TESH-1 For single TESH Cable

IEK-TESH-2 For two TESH Cables



Receiving, Storing and Handling . . .

1. Inspect materials for damage incurred during shipping.
2. Report damages to the carrier for settlement.
3. Identify parts against the packing list to ensure the proper type and quantity has been received.
4. Store in dry location.

Dimensions . . .

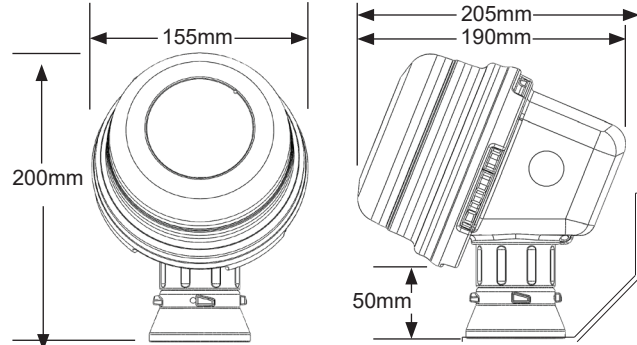

Warnings

- Due to the risk of electrical shock, arcing and fire caused by product damage or improper usage, installation or maintenance, a ground-fault protection device is required.
- Installation must comply with Thermon requirements (including form PN 50273U for Ex systems) and be installed in accordance with the regulations as per the norm EN IEC 60079-14 for hazardous areas (where applicable), or any other applicable national and local codes.
- Component approvals and performance ratings are based on the use of Thermon specified parts only.
- De-energize all power sources before opening enclosure.
- Avoid electrostatic charge. Clean only with a damp cloth.
- Keep ends of heating cable and kit components dry before and during installation.
- Minimum bending radius of heating cable is 6 times the cable outer diameter.
- Individuals installing these products are responsible for complying with all applicable safety and health guidelines. Proper Personal Protective Equipment (PPE) should be utilized during installation. Contact Thermon if you have any additional questions.

Tools Required

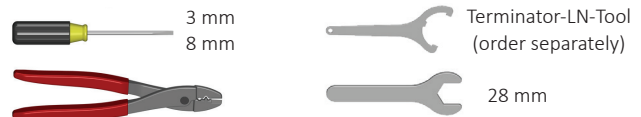

Certifications/Approvals

IP66; -60°C ≤ Ta ≤ +55°C T6, 85°C 16 Amps Max

-60°C ≤ Ta ≤ +50°C T5, 100°C 25 Amps Max

Ordinary & Hazardous Locations

Terminator ZT

FMG 10.0022X Ex db eb IIC T5-T6, Ex tb IIIC T100°C-T85°C

2809 Ex II 2 GD Ex db eb IIC T5-T6, Ex tb IIIC T100°C-T85°C FM10ATEX0058X

Terminator ZT-C

EPS 19.0094X Ex db eb IIC T5-T6, Ex tb IIIC T100°C-T85°C

2809 Ex II 2 GD Ex db eb IIC T5-T6, Ex tb IIIC T100°C-T85°C EPS 19ATEX1216X

Terminator™ ZT-(C)-R-WP INSTALLATION PROCEDURES

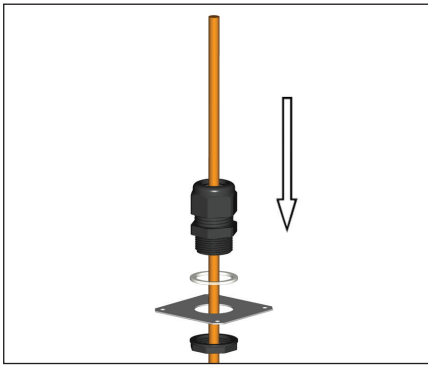

1. Slide IEK-TES Insulation entry kit components onto cable. (Order Separately)

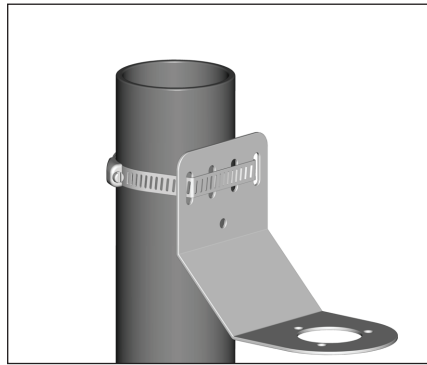

2a. Mounting Method 1: Secure wall mount bracket to mounting surface using pipe band provided with kits.

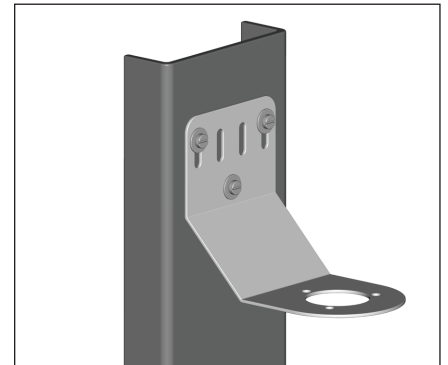

2b. Mounting Method 2: Secure wall mount bracket to mounting surface using customer supplied screws, flat washers, and nuts.

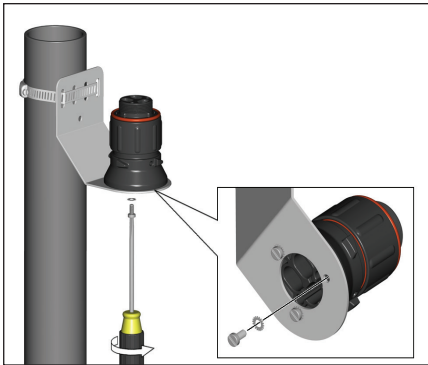

3. Mount expediter to bracket using M5 x 8 mm screws and M5 lock washers.

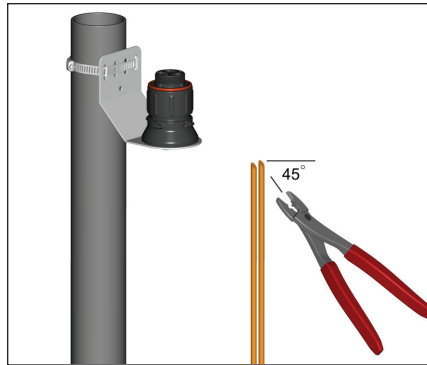

4. Cut end of cable at angle to aid in piercing grommet. Leave additional cable for expansion as needed.

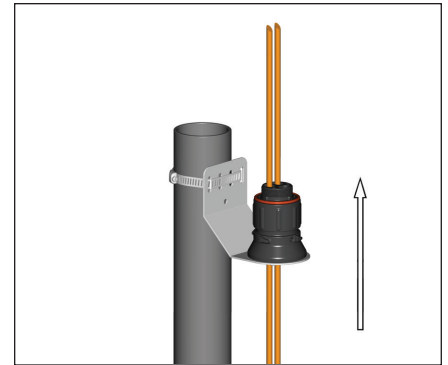

5. Insert cable into expediter.

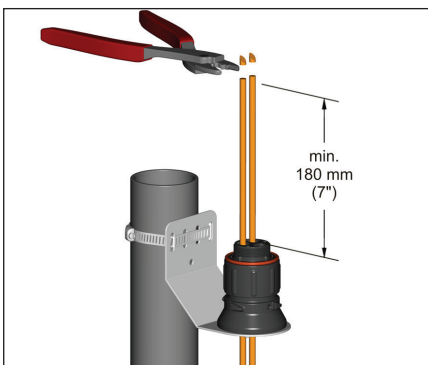

6. Cut off end of cable.

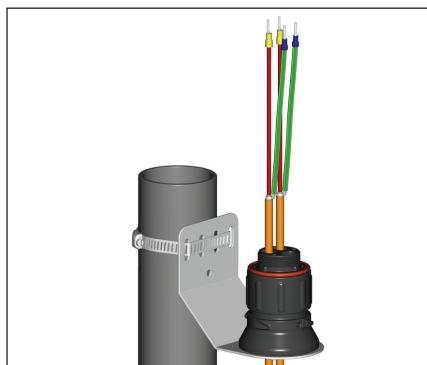

7. Terminate cable with appropriate PETK termination kit. Refer to PETK installation instructions.

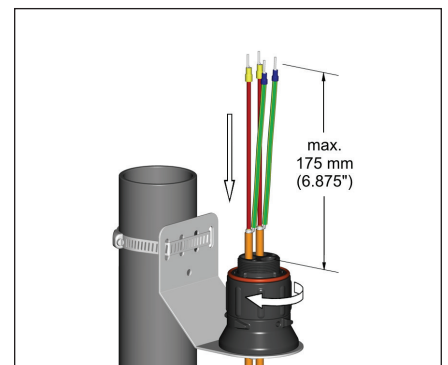

8. Push excess cable back through expediter. Tighten cap securely.

Terminator™ ZT-(C)-R-WP INSTALLATION PROCEDURES

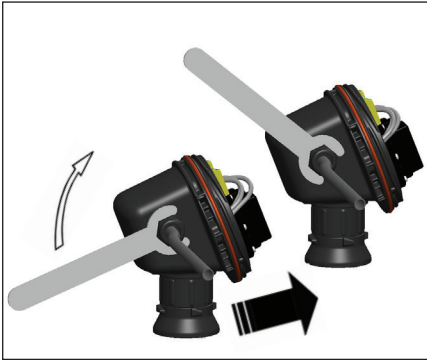

9. Remove M25 Dust Cap. Install M25 power gland (order separately) and M25 blind plug.

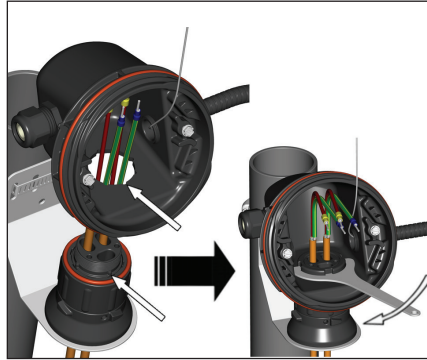

10. Take out thermostat. Mount junction box base on expediter. Make sure to align slots to properly orient junction box base. Tighten nut with Terminator-LN-Tool. If mounting horizontally, threaded gland holes must face downward.

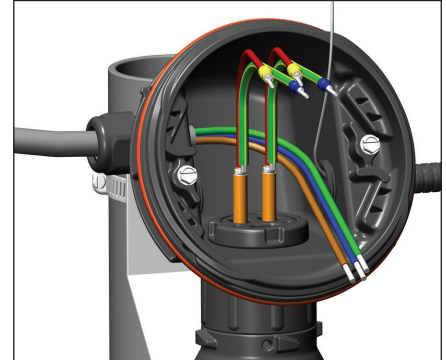

11. Install power cable.

Wiring Details

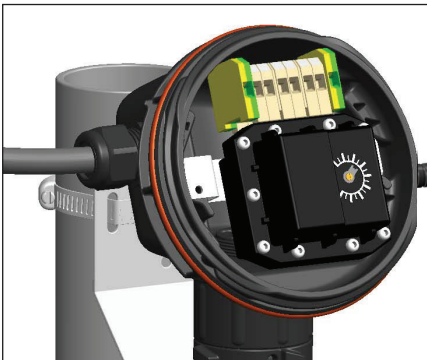

12. Install thermostat and complete system wiring. Terminal set screws shall be tightened to a torque value of 1.4 Nm (12.4 lb-in). See page 4 for wiring details. Set thermostat at desired setpoint.

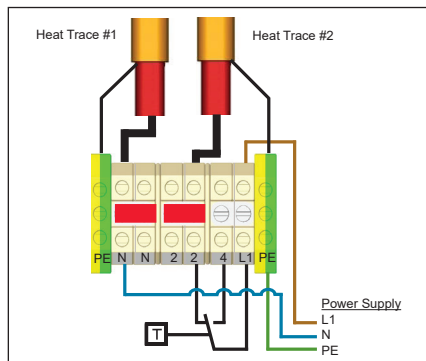

Thermostat Connection (2 Heating Cables)

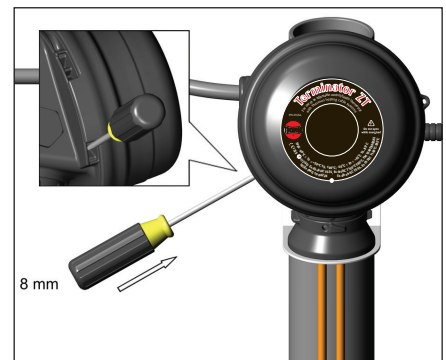

13. Install junction box lid and twist hand tight. Insert screwdriver into ratchet slots located on side of junction box base.

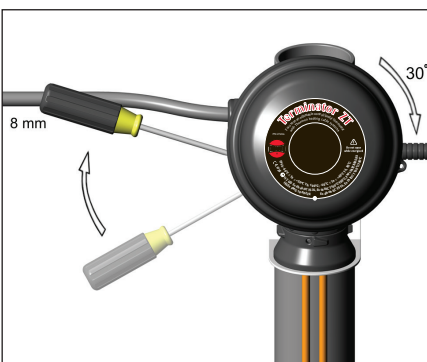

14. Use screwdriver to ratchet on junction box lid. Lid will rotate 30 degrees. To remove lid, repeat steps 13 and 14 but in the opposite direction.

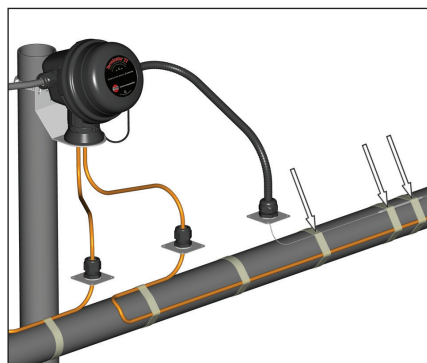

15. Fix thermostat bulb and capillary tube to pipe.

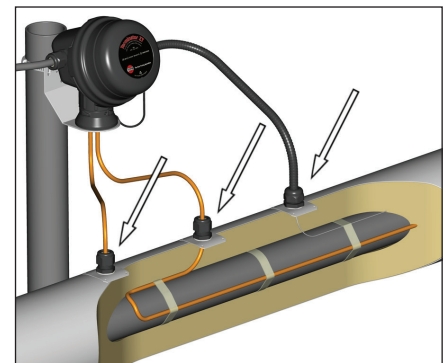

16. Install IEK insulation entry kit to seal heating cable and thermostat capillary penetration through insulation cladding.

