

# Terminator™ ZT-P-XP Terminator™ ZT-C-P-XP Thermostat Connection Kit INSTALLATION PROCEDURES



For Thermostat Connection (1-2 Heat Tracers)  
Applications for Use With Parallel Heat Tracers



# Terminator™ ZT-(C)-P-XP

The following installation procedures are suggested guidelines for the installation of the Terminator ZT-P-XP and ZT-C-P-XP Kits.

## Kit Contents



| Item | Quantity | Description  |
|------|----------|--|
| 1    | 1        | Expediter Assembly<br>Support Cap with O-Ring<br>Threaded Grommet Compressor<br>Grommet<br>Support Base with O-Ring  |
| 2    | 1        | Junction Box Lid   |
| 3    | 1        | Junction Box Base w/O-Ring and M25 Dust Cap  |
| 4    | 1        | Nut  |
| 5    | 1        | Banding  |
| 6    | 1        | Banding Guide  |
| 7    | 1        | Thermostat w/ Terminal Blocks (Refer to terminal specifications for maximum allowable wire size)<br><u>Thermostat Type</u><br>ZT-C-230 Vac<br>ZT-C-400 Vac<br><u>Terminals</u><br>4 mm <sup>2</sup> terminals<br>6 mm <sup>2</sup> terminals |
|      | 1        | Junction Box Cord  |
| 9    | 2        | Blind Plug   |

## Order Separately

### PETK Power and End Termination Kits (per cable)

- PETK-1 for RSX, VSX, VSX-HT, BSX
- PETK-2 for KSX, HTSX, USX
- PETK-3-ZT for HPT, FP

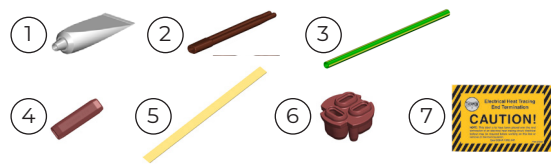

| Item | Quantity | Description                   |
|------|----------|-------------------------------|
| 1    | 1        | RTV Tube                      |
| 2    | 1        | Power Connection Boot         |
| 3    | 1        | Ground Sleeve                 |
| 4    | 1        | End Cap                       |
| 5    | 1        | Tape Strip (PETK-3-ZT only)   |
| 6    | 1        | Grommet (PETK-3-ZT only)      |
| 7    | 1        | End Termination Caution Label |

## Tools Required

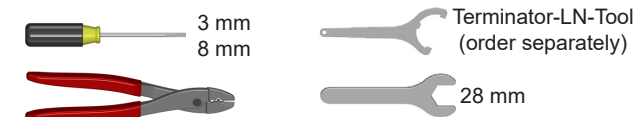

# INSTALLATION PROCEDURES

## Receiving, Storing and Handling

1. Inspect materials for damage incurred during shipping.
2. Report damages to the carrier for settlement.
3. Identify parts against the packing list to ensure the proper type and quantity has been received.
4. Store in a dry location.

## Dimensions

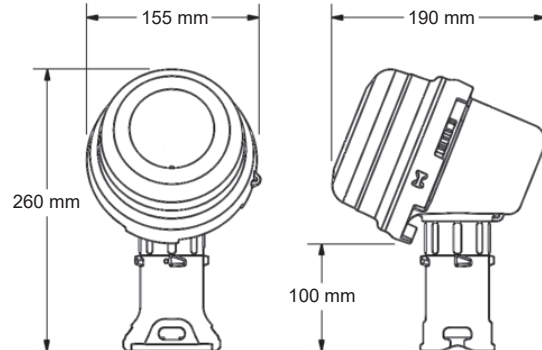

## Warnings

- Due to the risk of electrical shock, arcing and fire caused by product damage or improper usage, installation or maintenance, a ground-fault protection device is required.
- Installation must comply with Thermon requirements (including form PN 50207U for Ex systems) and be installed in accordance with the regulations as per the norm EN IEC 60079-14 for hazardous areas (where applicable), or any other applicable national and local codes.
- Component approvals and performance ratings are based on the use of Thermon specified parts only.
- De-energize all power sources before opening enclosure.
- Avoid electrostatic charge. Clean only with a damp cloth.
- Keep ends of heating cable and kit components dry before and during installation.
- Minimum bending radius of heating cable is 32 mm (except HPT is 57 mm and FP is 19 mm).
- Individuals installing these products are responsible for complying with all applicable safety and health guidelines. Proper Personal Protective Equipment (PPE) should be utilized during installation. Contact Thermon if you have any additional questions.
- Consult the manufacturer for dimensional information on the flameproof joints for repair.

## Specific Conditions of Use

1. Consult the manufacturer for dimensional information on the flameproof joints for repair.
2. Avoid electrostatic charge. Clean only with a damp cloth.
3. T5 and T100°C for switching amperage of thermostat limited to 25 Amps maximum.
4. T6 and T85°C for switching amperage of thermostat limited to 16 Amps maximum.

## Certifications/Approvals

IP66; -60°C ≤ Ta ≤ +55°C T6, 85°C 16 Amps Max  
-60°C ≤ Ta ≤ +50°C T5, 100°C 25 Amps Max  
Ordinary & Hazardous Locations

Terminator ZT

IEC FMG 10.0022X Ex db eb IIC T6...T5 Gb  
Ex tb IIIC T85°C...T100°C Db

0344 Ex II 2 GD Ex db eb IIC T6...T5 Gb, Ex tb IIIC T85°C...T100°C Db  
FM10ATEX0058X

Terminator ZT-C

IEC EPS 19.0094X Ex db eb IIC T5-T6, Ex tb IIIC T100°C-T85°C

0344 Ex II 2 GD Ex db eb IIC T5-T6, Ex tb IIIC T100°C-T85°C EPS  
19ATEX1216X

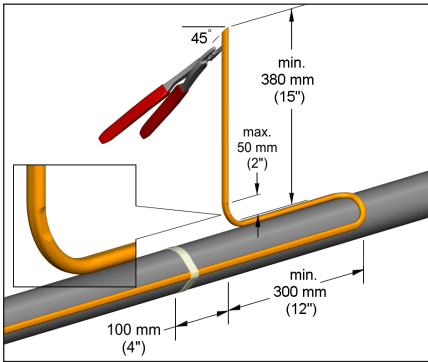

**1.** Locate bus connection (HPT and FP only) and cable as shown. Cut end of cable at angle to aid in piercing grommet. Leave additional cable for expansion loop. See page 5 for multiple cable installation tips.

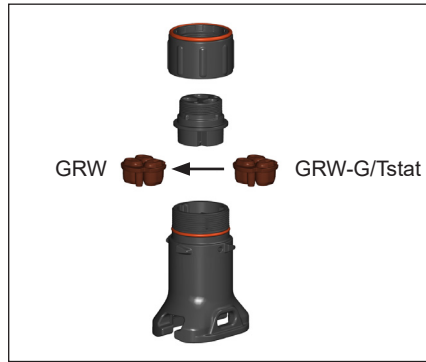

**2.** For HPT and FP cable, exchange grommet in Terminator with grommet provided in PETK-3-ZT.

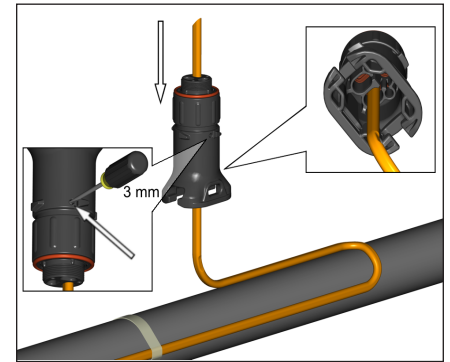

**3.** Insert cable into expediter. If mounted on bottom or side of pipe, punch out weep hole.

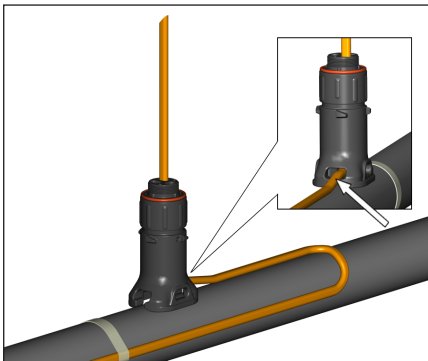

**4.** Slide expediter toward pipe and route cable through support base entry.

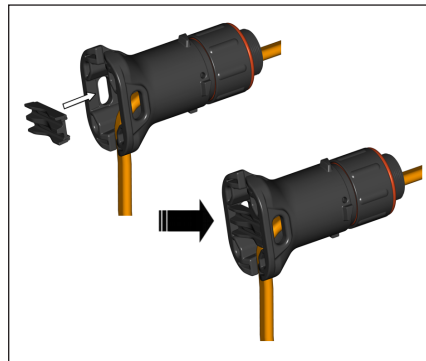

**5.** Insert banding guide into expediter and snap into place.

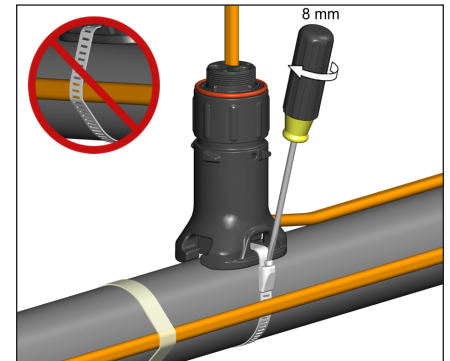

**6.** Mount expediter to pipe using pipe band. Do not band over cable.

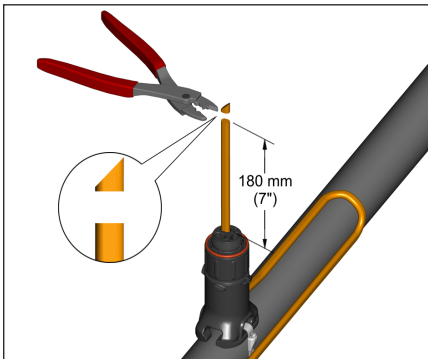

**7.** Cut off end of cable.

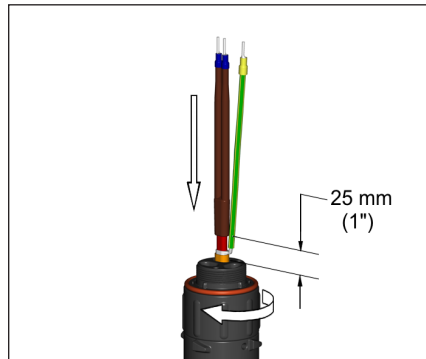

**8.** Terminate cable with appropriate PETK termination kit. Refer to PETK installation instructions. Push excess cable back through expediter. Tighten cap securely. Tape cable expansion loop to pipe.

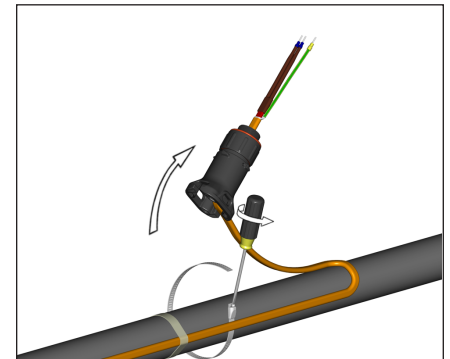

**9.** Remove expediter from pipe by removing pipe band.

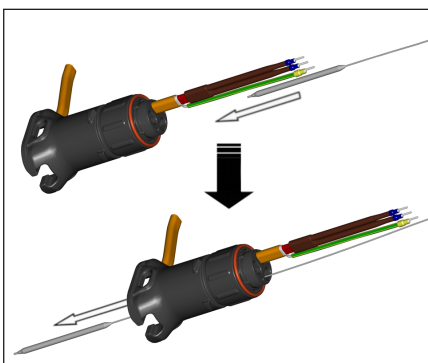

**10.** Route thermostat bulb through nut and expediter opening in junction box base. If necessary, apply lubricant (user supplied) to end of thermostat bulb. Slide through conical grommet hole. Push excess capillary tube through expediter.

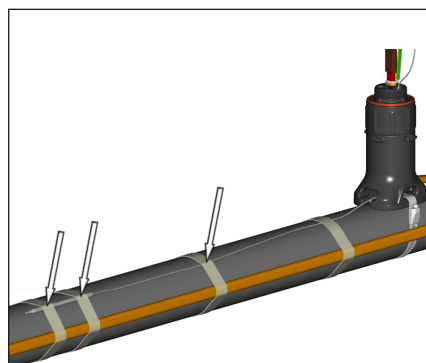

**11.** Fix thermostat bulb and capillary tube to pipe.

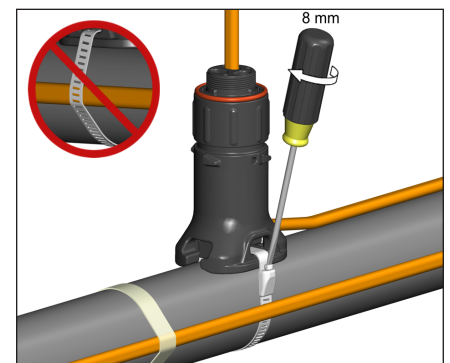

**12.** Mount expediter to pipe using pipe band. Do not band over cable. Tape cable expansion loop to pipe.

# Terminator™ ZT-(C)-P-XP

## INSTALLATION PROCEDURES

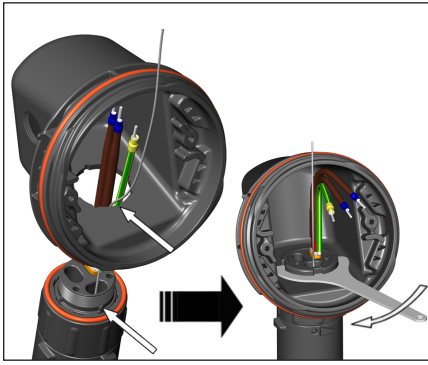

**13.** Take out thermostat. Mount junction box base on expediter. Make sure to align slots to properly orient junction box base. Tighten nut with Terminator-LN-Tool. If mounting horizontally, threaded gland holes must face downward.

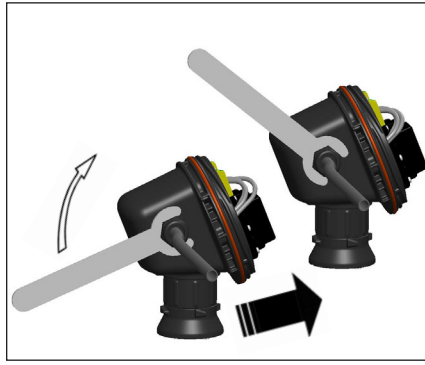

**14.** Remove M25 dust cap. Install M25 power gland (order separately) and M25 blind plugs.

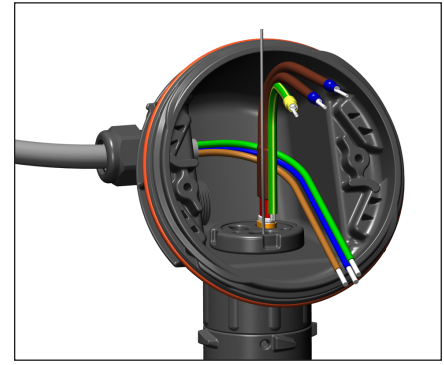

**15.** Install power cable (if necessary).

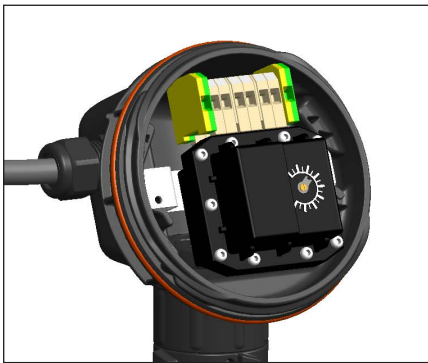

**16.** Install thermostat and complete system wiring. Terminal set screws shall be tightened to a torque value of 1.4 Nm (12.4 lb-in). See page 5 for wiring details. Set thermostat at desired setpoint.

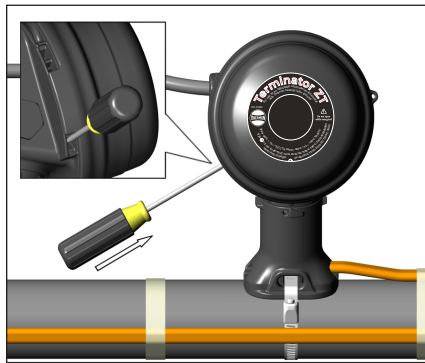

**17.** Install junction box lid and twist hand tight. Insert screwdriver into ratchet slots located on side of junction box base. Use screwdriver to ratchet on junction box lid. Lid will rotate 30 degrees.

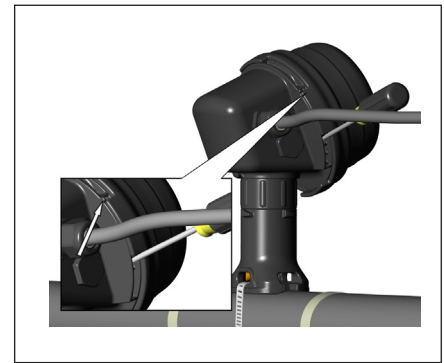

**18.** Lid latch mechanism fully engaged. To remove lid, repeat step 17 but in the opposite direction.

### Wiring Details

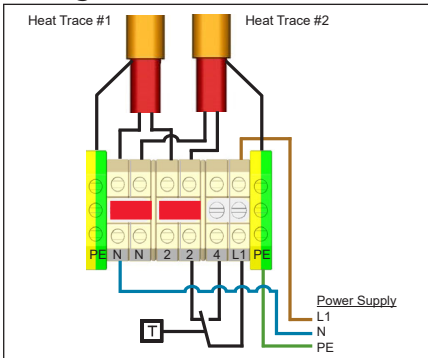

Thermostat Connection (1 or 2 Heating Cables)

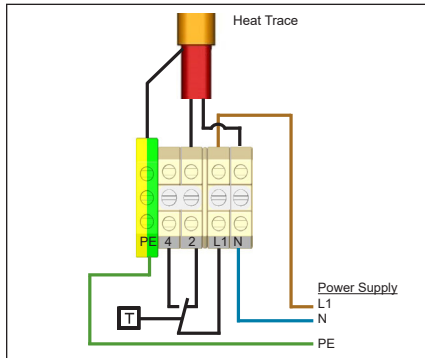

Thermostat Connection (1 Heating Cable Shown) 400 Vac Option.

### Two-Cable Layout Tips

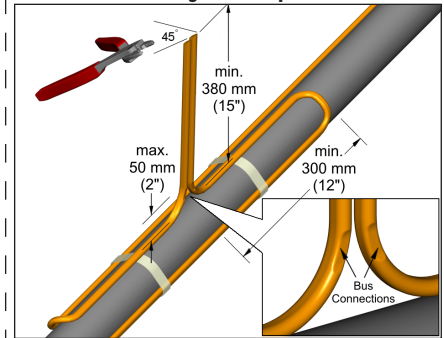

Locate bus connection (HPT and FP only) and cable as shown. Cut end of cable at angle to aid in piercing grommet. Leave additional cable for expansion loop.

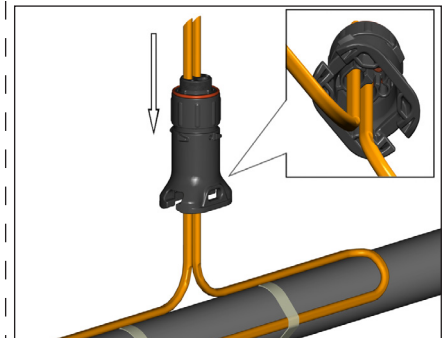

Insert two cables into expediter.

Note: For HPT and FP cable, exchange grommet in Terminator with grommet provided in PETK-3-ZT.

