

**WarmTrace™**  
Systems for Hot Water Temperature Maintenance

**INSTALLATION INSTRUCTIONS**



**The Heat Tracing Specialists®**

## INSTALLATION INSTRUCTIONS



### Contents

- Safety Precautions ..... 2
- Using the Guide ..... 2
- Receiving and Storing Cable ..... 3
- Preinstallation Checklist ..... 3
- Identifying the Materials Received ..... 3-5
- Cable Installation ..... 6-7
- TracePlus Quick Connection Kits ..... 8-9
- End Terminations ..... 10
- Cable Testing ..... 11
- Thermal Insulation ..... 11-12
- Connection to Power ..... 13
- System Start-Up/Maintenance ..... 13
- Troubleshooting ..... 15-16
- Appendix ..... 17



**The Heat Tracing Specialists®**

# WarmTrace™ Systems for Hot Water Temperature Maintenance

## Safety Comes First...

The safety and performance of a heat tracing system depends on how the system was designed, installed and eventually maintained. Improper handling, installation or maintenance of the system could result in underheating or overheating of the water or damage of the heat tracing cable. This damage could result in electrical shock, fire or system failure. The information, instructions, testing procedures and warnings addressed in this guide are important. To minimize these risks, read this guide prior to starting any heating cable or component installation and follow the instructions carefully.

## Approvals/Code Compliance...

Thermon's WarmTrace system comprised of HSX 2100 heating cable and accessories carry Australian Standard Certified Product Approvals (AS/ANSI IEEE 515.1 LIC SMK 2408) and is also approved for hot water temperature maintenance by:



**Underwriters Laboratories Inc.**  
134N E56615



**Canadian Standard Association**  
Designation 3A



◁ VDE ▷ CE  
Reg. No: 3701 to 3706

WarmTrace systems comply with the applicable requirements of the following code agencies:

- BS 7671:1992
- NEC
- Uniform Plumbing Code
- BOCA
- Southern Building Code Congress
- National Standard Plumbing Code

Be sure the electrical power connections comply with the National Electrical Code (NEC) article 427 and any other applicable national (AS/NZ Codes), state or local codes.

WarmTrace systems also meet or exceed the requirements of the IEEE Recommended Practice for the Testing, Design, Installation, and maintenance of Electrical Resistance Heat Tracing for Commercial Applications, IEEE Standard 515.1-1995

## How to Use this Guide...

This installation, operation and start-up guide is broken up into sections outlined in the index on page 1. Familiarize yourself with the entire guide prior to installing any heating cable or components. Throughout this guide, The following symbols will appear to emphasize a particular key point or an installation tip:



This symbol is intended to alert the user to the presence of important installation, operation or maintenance instructions within the guide.



Thermon (recommended) Installation Procedure. Identifies an installation, operation or start-up tip that could save time, installation materials or make for an improved system.

## Tools Required for Installation...

The following hand tools are recommended for a proper installation of a WarmTrace system:



1. Scissors
2. Utility knife
3. Cable cutters

In addition to the hand tools listed, a DC voltage "Megger" will be required to test the cable at various times during the installation process. Refer to the Cable Testing Section (pg. 10-11) for details on the equipment necessary to accomplish this procedure.

**Note: All circuit testing, power connection and commissioning must be done by a qualified electrical tradesperson.**



The Heat Tracing Specialists®

# INSTALLATION INSTRUCTIONS

## Upon Receiving Heating Cable...

Inspect materials for damage incurred during shipping. Report any damages to the carrier for settlement.

Identify the cable to ensure the proper type and quantity has been received. The catalogue number of the heating cable is printed on the cable jacket along with numerous additional information.

To locate the catalogue number look immediately after the words "SELF-REGULATING HEATER" as shown below.

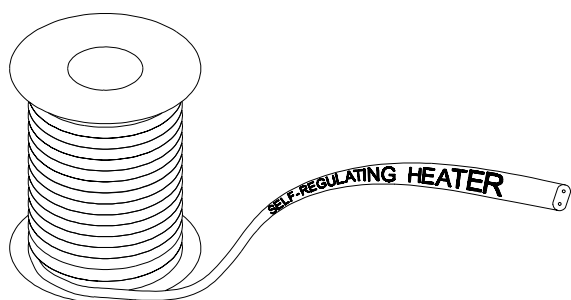

The cable should be identified within the list below.

Cable Type (Catalogue No.)	Outer Jacket Colour	Service Voltage (Vac)
HSX 2105-2	Blue	240
HSX 2120-2	Green	240
HSX 2140-2	Red	240



**Caution: Do not connect power to heating cable while it is still on the reel or in shipping carton.**

## Storing Cable Prior to Installation...

Store cable and accessories in a clean and dry place where temperatures will be between -40° C and +60° C.



**Do not allow water ingress to cable ends.**

## Prior to Installation Cable...

### Step 1: Verify electrical resistance with a Megger

- Refer to the Cable Testing Section (pg.10) these installation instruction for details.

### Step 2: Inspect the Piping to be Heat Traced.

- Verify that the pipe has been pressure tested, and that all pipe supports are in place.
- Compare layout of the installed piping vs. plumbing drawings.

### Step 3: Plan the Installation

- Not every metre of hot water supply piping will require heating cable. Note the extent of heat tracing required by reviewing.
  1. Project specification
  2. Plumbing drawings
  3. Drawings supplied by Thermon (if a drawing package was part of the heat trace system)

- Allow sufficient cable to cover the longest runs to minimize spoils first. This will ensure that no additional cable or splice kits will be required.

- The extent of heat tracing, location of power connection points, splices and end terminations can be temporarily identified with marking ribbon or spray paint.

### Step 4: Identify the Heat Trace Materials

- The cable should have already been identified using the table at left. Be sure to make note that not more than one water maintain temperature is required, and therefore more than one HSX 2100 cable, may be required for the project.

- Familiarize yourself with the connection kits and accessory components included with the bill of materials.

- Use the drawings and descriptions located on page 4 and 5 to match the catalogue number and description with the items received as part of the bill of materials.

# WarmTrace™ Systems for Hot Water Temperature Maintenance

## TracePlus Quick Connection Kits...

### TracePlus PowerSnap 1 (Circuit Fabrication - 1 Cable)

1. Cable Termination Assembly
2. Pipe Attachment Straps
3. ET-6 End Cap
4. RTV Adhesive
5. Labels (End Termination & UL)
6. Cable attachment mounts
7. Gland



### TracePlus PowerSnap 2 (Circuit Fabrication - 2 Cable)

1. Cable Termination Assembly
2. Pipe Attachment Straps
3. ET-6 End Cap (2)
4. RTV Adhesive
5. Labels (End Termination (2) & UL)
6. Cable attachment mounts
7. Gland

### TracePlus TeeSnap (Connects 3 Cables)

1. Cable Termination Assembly
2. Pipe Attachment Straps
3. ET-6 End Cap
4. RTV Adhesive
5. Labels (End/Splice Termination & UL)
6. Cable attachment mounts



### TracePlus SpliceSnap (Connects 2 Cables)

1. Cable Termination Assembly
2. Pipe Attachment Straps
3. ET-6 End Cap
4. RTV Adhesive
5. Labels (End/Splice Termination & UL)



All warning labels must be applied and correctly positioned on fittings and on the piping/insulation.



# INSTALLATION INSTRUCTIONS

## General Installation Accessories...



### PF-1 Tape

- Temperature resistant polyester fibre tape.
- Used to attach cable to pipe every 300mm.



### Caution Label

- Placed every 3m along heat traced pipework.



### ET-6C-Com End Termination

- Includes RTV, ET-6, Caution Label.
- Terminate cable at dead ends.

# WarmTrace™ Systems for Hot Water Temperature Maintenance

## Installing Cable on Pipe...

The HSX 2100 cable will be installed on the pipe in a parallel pass. There is no need for spiral wrapping. Locate the cable in the 4 or 8 o'clock position wherever possible.

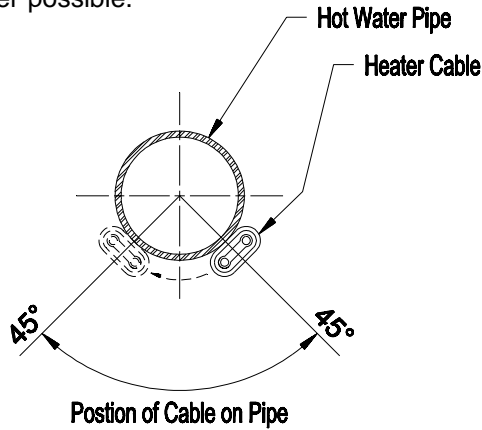

## Attaching Cable to the Pipe...

HSX 2100 cable is held in place with temperature rated polyester fiber tape (catalogue number PF-1). Pipe should be pressure tested clean and free of grease. Circumferential bands of tape should be installed at 300mm intervals to ensure the cable maintains proper contact with the pipe.

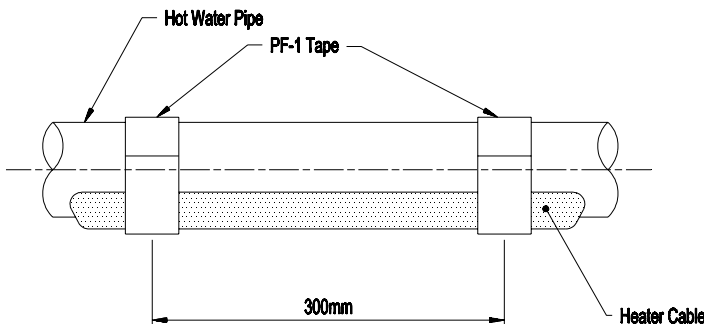

## Tape Allowance Chart...

Pipe Size (mm)	13	32	38	50	64	75
Metres of Pipe/Roll of Tape	110	79	67	55	50	45

Where space is a problem, Thermon approved plastic cable ties may be used on the same intervals as tape. **Do not over tighten cable ties.**



**Caution: Do NOT attach cable to pipe with metal hose clamps, metal strapping, tie wire or similar materials. Damage to the cable and system could result.**



**Avoid pinch points when installing cable.** Over the course of time, the pipe will move due to vibration, thermal expansion, contraction and building settling. Do not allow the heating cable to bind between items such as:

**Pipe Supports:** Run the heating cable on the outside of any pipe hanger or support that comes in contact with the pipe. Thermon recommends the use of insulated pipe supports to prevent additional heat loss at the point of support.

Install Cable like this...

Not This...

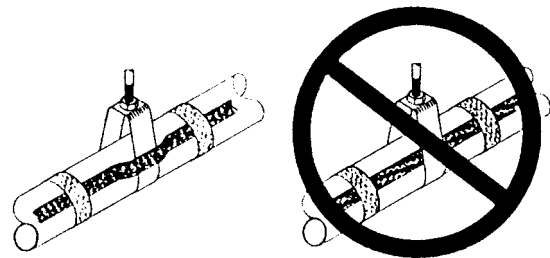

**Wall or Floor Penetrations:** The heating cable must be protected when passing between floors or through a wall. This can be accomplished with pieces of conduit or channel. If the penetration requires fire protection, the conduit or channel may be caulked with an approved caulking material.

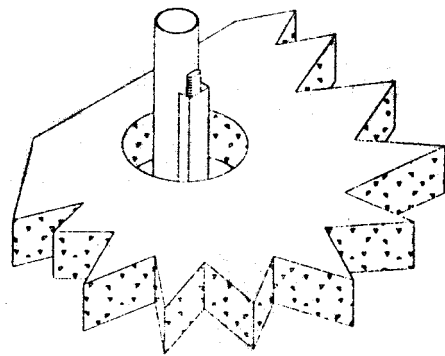

**Pipe Support:** Cork or Polyurethane insulation insert. Cut small hole for cable to be passed through.

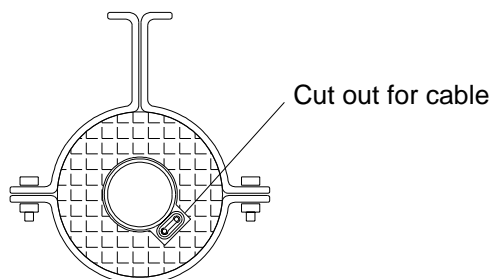



# INSTALLATION INSTRUCTIONS

## Locating Power, Tee & End Terminations...

Refer to the plumbing, electrical or Thermon supplied drawings to determine the locations for connections and terminations. The symbols below are routinely used to show the various components of a heat traced hot water supply system. (Note that the electrical drawings will typically only show the power connection points.)

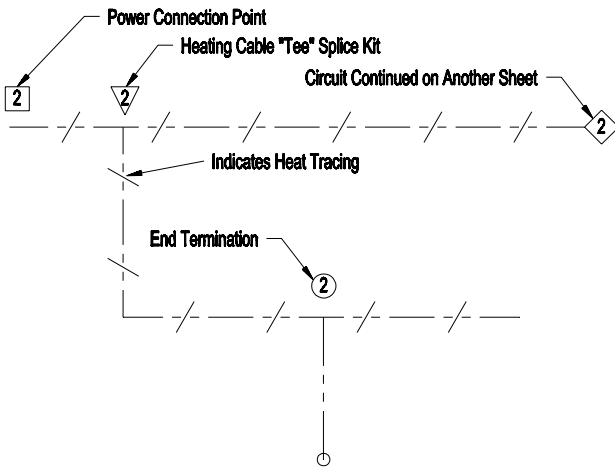

**Power Connection Points:** The power (electrical) connection points must remain accessible, even after the building is completed. If the facility will be finished out with a suspended ceiling, power connection points can be located anywhere that is convenient (and accessible to electrical power). Should the finished ceiling be permanent, each power connection point must be located within reach from an access door.

**Tee Splice Connections and End Terminations:** Per the NEC and Thermon's UL Listing, tee splice connections and end terminations do not require accessibility and therefore do not require access doors. Thermon does recommend that wherever possible, all connections and terminations be located in areas that allow future access should changes or additions to the plumbing system be needed.

## Maximum Circuit Lengths...

To prevent excessive electrical currents at the branch circuit breaker supplying power to the heating cable, the maximum circuit length shown in the chart below must be observed.

Catalog Number	Service Voltage (VAC)	Steady-State Current Draw amps/m	Breaker Size	
			15 Amp	20 Amp
HSX 2105-2 (Blue)	240	0.020	350m	425m
HSX 2120-2 (Green)	240	0.050	125m	175m
HSX 2140-2 (Red)	240	0.060	93m	130m

### Notes:

1. These maximum circuit lengths are defined as the total length of cable that can be fed from a single power connection point, inclusive of all splices.
2. Note that longer circuit lengths may require larger circuit breakers.
3. Be sure to verify the available amperages of the branch circuit breakers supplying power to the heat tracing.
4. If the power supply voltage will be different than that listed in the chart above, contact Thermon or your Thermon factory representative before installing any cable.
5. Any number of shorter heat tracing circuits can be energized from a single branch circuit breaker so long as the total metreage of heating cable does not exceed the metreage stated for a given branch circuit breaker's amperage rating.



## Installations With TracePlus Quick Connection Kits...

The following steps detail the fabrication of the following TracePlus quick connection kits.

**PowerSnap 1** Circuit Fabrication Kit (for connecting power to one HSX heating cable).

**PowerSnap 2** Circuit Fabrication Kit (for connecting power to two heating cables).

**TeeSnap** Tee Splice Fabrication Kit (for connecting three HSX heating cables)

**SpliceSnap** Inline Splice Fabrication Kit (for connecting two HSX heating cable)

The following steps detail the fabrication of the following TracePlus quick connection kits.

Preparing and terminating the HSX cable is the same for each of the kits, simply repeat steps 1 through 9 outlined

**To Make an End Termination, Go To Pg. 9.**

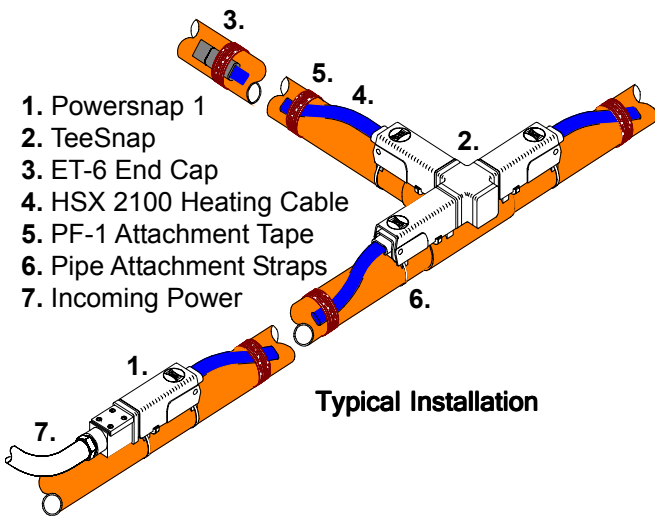

1. Powersnap 1
2. TeeSnap
3. ET-6 End Cap
4. HSX 2100 Heating Cable
5. PF-1 Attachment Tape
6. Pipe Attachment Straps
7. Incoming Power

**Typical Installation**

**Locating the Kits:** Install the Snap kits in the positions shown in the typical installation above. Should space or accessibility constraints prevent this placement, the kits may be installed on the underside of the piping or at either side. Do not install the kits on adjacent piping and allow the heating cable to run through the air between the pipe.



Begin installation at the power supply point and layout heating cable on the pipe. For each heat tracing circuit or area within the facility, install all of the cable and then go back and make up the terminations.

1. Each unit is shipped assembled and must be partially disassembled to facilitate installation. the major components are:

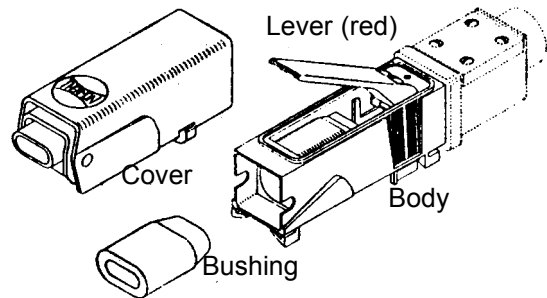

2. To remove the cover, place a small screwdriver into the slot located on each side and gently pry while lifting the cover. As the cover opens, slide it away from the body. A slight shake will expel the bushing from the body. Open, but do not remove the red cable clamping lever.

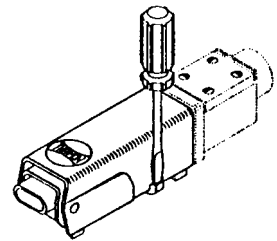

3. Determine and mark the location of the fitting on the pipework.

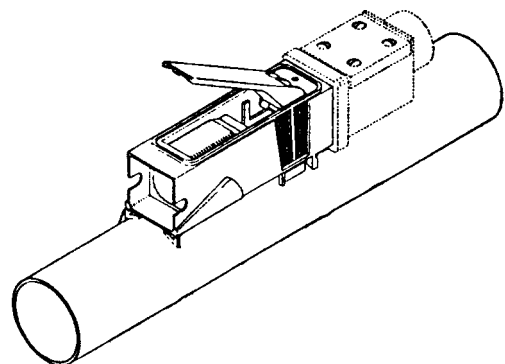

**Both PowerSnap 1 and 2 employ segregated separate compartments for connection of the power cable and the heat trace cable.**

# INSTALLATION INSTRUCTIONS

4. Cut the heating cable to the proper length using the white reference stripe (arrow) located on either side of the kit's body. The cut should be square to the cable.

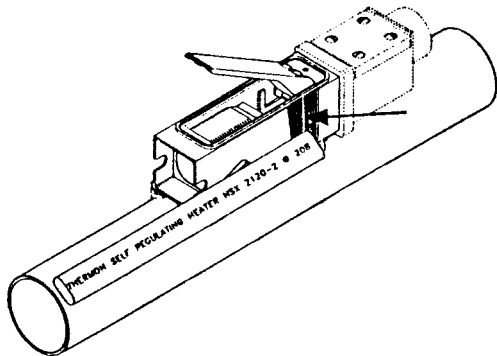

5. Slide the cover 75mm - 100mm over the heating cable followed by the bushing. The tapered end of the bushing should face the cut end of the cable. Leave 30mm of cable past the end of the bushing.

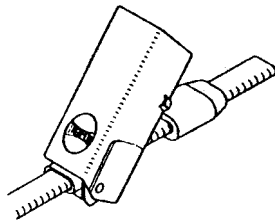

6. With a utility knife, remove 30mm of the heating cable outer jacket. Do not apply so much pressure as to cut or damage the metallic braid.

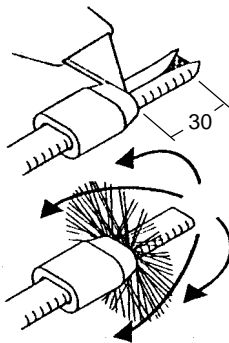

7. Fold the metallic braid back over the bushing. Keep the braid clear of the bottom side of the bushing to allow proper ground contact when the bushing is inserted into the body.



8. Gently score the aluminium foil with tip of utility knife and peel away, before inserting into fitting. Do not remove any of the gray primary dielectric insulation covering the heating cable.

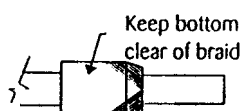
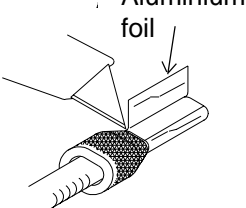

Aluminium foil barrier is conductive and must be removed before terminations are completed.

9. Insert the prepared cable end and bushing into the base while the red cable clamp lever is raised. Push the cable in past the strain relief point (white tabs) until it touches the red lever. The bushing will fill the recess when the cable is properly seated.

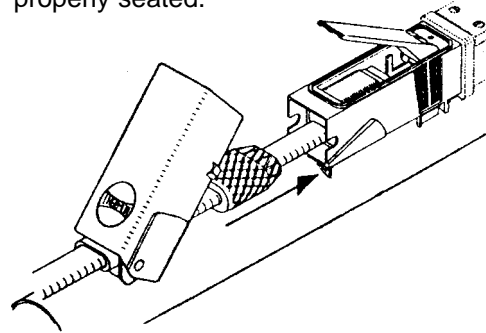

10. Close the red cable clamping lever (1.) and maintain pressure on the lever while sliding the cover (2.) until the gasketed swivel end fits into the recess in the body. Release pressure on the lever while closing the cover (3.) manipulate fitting by rolling side to side in hands to align cover and apply pressure on the cover until it SNAPS in place.

11. Use mounting straps provided to fix fitting to pipe.

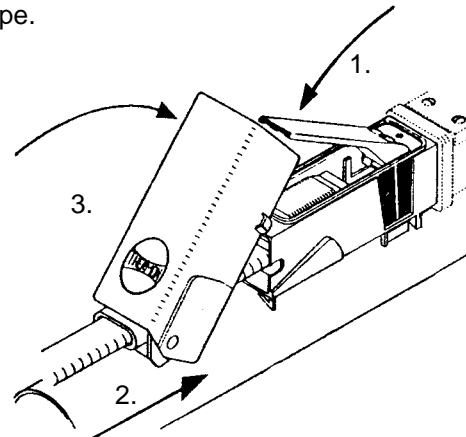

Cover must snap shut firmly be sure this procedure is followed.

Repeat Steps 1 Through 11 for Each Leg of a PowerSnap 2 or TeeSnap kit. Attach UL label to cover.

Heating cable must be megger tested before connecting to power. Refer to the Cable Testing Section (pg. 10-11) of these Installation Instructions for details.

# WarmTrace™ Systems for Hot Water Temperature Maintenance

## End of Circuit Terminations...

The following steps detail the procedure for terminating the ends of HSX 2100 circuits. Follow these steps for TracePlus Quick Connection Kits (PowerSnap 1, PowerSnap 2, SpiceSnap and TeeSnap).

To make an end termination the following parts (included with each of the above mentioned kits) will be needed:

1. ET-6 End Cap
2. RTV adhesive



**Caution: The end of each run of heating cable must be properly terminated. DO NOT use electrical tape, wire nuts or other means to terminate the cable.**

1. After determining the location of the end of a heat tracing circuit cut the cable square to the run of the cable.

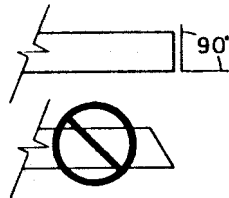

2. With a utility knife, remove 15mm of the heating cable outer jacket and trim away the exposed metallic braid with scissors. Gently score the aluminium foil layer and peel away. Do not remove any of the gray primary dielectric insulation.

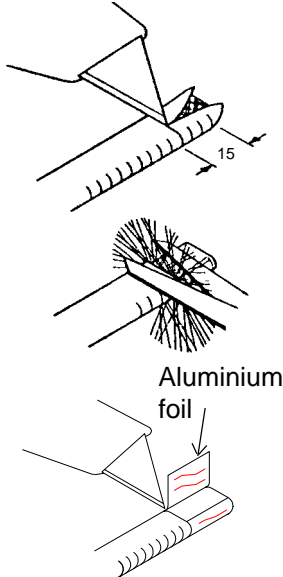

**Caution: Do NOT connect the bus wires together at the end termination. Doing so will result in a direct short and could damage the cable**



3. Apply a generous coating of RTV sealant to both the cable end ( the 15mm of trimmed cable plus 15mm of the outer jacketed cable) and the inside of the ET-6 end cap. With a twisting motion, slide the end cap over the cable until it completely covers the over jacket. Squeeze out any air pockets that are trapped in the end cap.

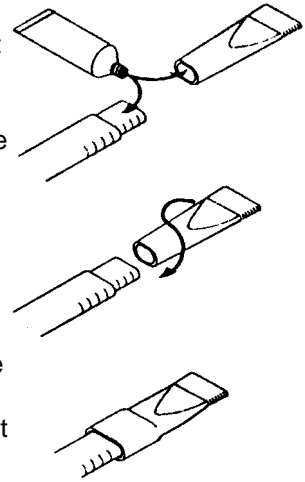

Record the location of end terminations on the plumbing drawings after each termination has been completed. This will ensure that no terminations are overlooked and will document the extent of heat tracing on the drawings

## Cable Testing...



**To be carried out only by Qualified Electrical Trades Personnel only.**

At various times during the installation process, the heating cable should be tested to ensure electrical resistance integrity. HSX 2100 heating cable should be tested with a 2,500 Vdc is megohmmeter (megger) between the heating cable bus wires and the heating cable's metallic braid. While a 2,500 Vdc megger is recommended, the minimum acceptable level for testing is 1,000 Vdc. Specifically, these megger tests should be conducted:

- a. While the cable is still on the reel(s), prior to installation;
- b. After installation of heating cable and completion of circuit fabrication kits (including any splice kits) but prior to installation of thermal insulation;
- c. After installation of thermal insulation but prior to installation of wall or ceiling materials;
- d. Prior to connection of power of the heating cable circuit; and



# INSTALLATION INSTRUCTIONS

## Cable Testing cont...

- e. As part of a routine maintenance program that includes testing after any work (repairs or alterations) is performed on or near the heat traced piping.



**Caution: Megohmmeters produce high DC voltage potential and can emit electrical shocks. Read and follow the operation procedures for the megger being used**

Megger testing is a pass/fail test with minimum acceptable level being 20 megohms regardless of the length of the circuit

The test consists of:

- Step 1: Connecting the negative (-) lead of the megger to the heating cable's metallic braid;
- Step 2: Connecting the positive (+) lead of the megger to the heating cable bus wires.
- Step 3: Applying DC voltage potential to the cable at the stated level; and
- Step 4: Measuring, recording and documenting the resistance level for verification to the construction manager and the Thermon factory representative (required for product warranty).

To perform the megger test on HSX 2100 cable follow the example that matches the stage of installation and the style of connection kit being used. Record and document the tests results for future use. QC-3-Com (See appendix)

## While cable is still on the reel...

Prepare test end of cable by removing 75mm - 100mm of outerjacket, twisting braid into a pigtail, removing 25mm - 50mm of gray primary dielectric, stripping the black matrix from the bus wires and twisting the bus wires together. The reel end of the cable must be checked to ensure that the metallic braid is separated from the area of the bus wires and the black conductive matrix.

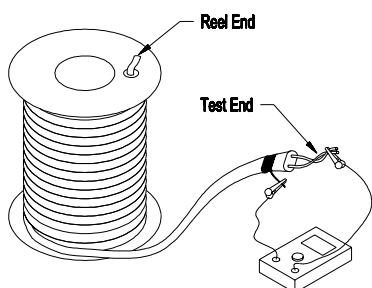

## Testing PowerSnap Fittings...

Remove the cover to the terminal block area of the PowerSnap. Connect the negative lead to the center ground terminal and the positive lead to one of the bus wire terminals. Test and repeat for the other bus terminal.

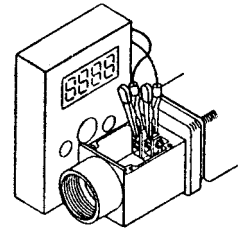

**As part of routine maintenance or after repairs...**

This megger test should be conducted at the power distribution panel by a qualified electrician.

**Cable test details to be recorded on form QC-3-Com document see page 17.**



**The supply earth must not be disconnected from the Earth braid while the heat tracing is still energised**

## Thermal Insulation...

Thermal insulation is critical to the overall performance of a heat traced hot water supply system. The following insulation schedule must be followed to ensure maintain temperatures are within the desired range. Variations to this insulation schedule could result in maintenance temperatures different than designed and required.

### Foil Faced Fibreglass (SPI) Insulation Schedule for WarmTrace Systems 45° C, 50° C, 60° C

Insulation Thickness	Nominal Pipe Size	Nominal Insulation Size
25mm	15mm	20mm
	20mm	25mm
	25mm	32mm
38mm	32mm	40mm
	40mm	40mm
	50mm	50mm
50mm	65mm	65mm
	80mm	80mm
	100mm	100mm

Notes:

- 1. Variations of insulation type and thickness must be referred to Thermon for advice.

## Thermal Insulation cont...

1. Nominal insulation size is increased by one pipe diameter for piping 32mm and smaller to accommodate the heating cable.
2. Insulation to be installed as per manufacturer's recommendations.
3. Complete closure of insulation joints is required to ensure no heat loss occurs



**Caution: Do NOT use staples to secure the insulation vapor barrier. Damage to the cable could occur.**

After the thermal insulation is installed, labels identifying the presence of heat tracing must be installed. At all accessible points of the installation, including access doors to ducts and service areas. These labels are typically installed on alternate sides of the pipe at 3m intervals. Additional labels identifying splices and end terminations are included with each kit and should be installed at the appropriate location for future reference.

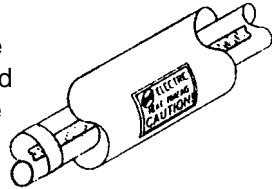

**Insulation to be installed to manufacturer's recommendations ensure complete closure of all joints and seams to avoid heat loss.**

Ensure insulation seam is at least 90° from cable position.

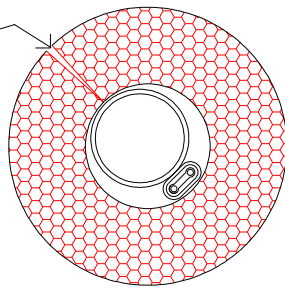

**A moisture proof weather barrier surrounding the thermal insulation must be provided for outdoor applications.**

## Connecting to Power...



**Caution: Final electrical connections for the heating cable should be performed by a qualified electrician.**

The power supply to the heat tracing will be 240 Vac. The voltage of the installed HSX 2100 cable can be verified by reading the cable identification printed on the cable jacket. Following the word

“Thermon Self-Regulating Heater” and the specific cable catalogue number (i.e. 240 Vac)

Verify the cable catalogue number, and the length of the heat tracing circuit. Using the chart below verify that the maximum circuit length is not exceeded for the circuit breaker feeding power to the heat tracing.

Catalog Number	Service Voltage (VAC)	Steady-State Current Draw amps/m	Breaker Size	
			15 Amp	20 Amp
HSX 2105-2 (Blue)	240	0.020	350m	425m
HSX 2120-2 (Green)	240	0.050	125m	175m
HSX 2140-2 (Red)	240	0.060	93m	130m

**Attention: the 1996 NEC code, Article 427-22, Equipment Protection, states “Ground -fault protection of equipment shall be provided for each branch circuit supplying electric heating equipment. Under AS3000 wiring code RCD's are not mandatory for hot water installations. Thermon's policy is that RCD's are 'Highly Recommended**

To meet this code requirement Thermon recommends the use of branch circuit breakers equipped with 30 mA protection. 5 mA GFCI should not be used as nuisance tripping may result.



**Earth (main supply) must not be disconnected whilst heat tracing circuit is energised.**





# INSTALLATION INSTRUCTIONS

## End of Circuit Terminations...

1. The assembled kit should look like the drawing below. No exposed end(s) of heating cable should be visible.

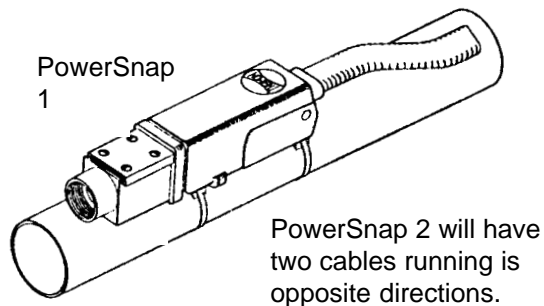

2. Remove the 4 screws on the terminal block cover to expose the integral terminal block. The raised center screw is for the circuit's ground path. The two outboard terminals are for active and Neutral connections.
3. The heating cable should be megger tested prior to connecting power (see Cable Testing on page 10-11).
4. Either hard wire to supply source or utilize 3 core flex connection to GPO.

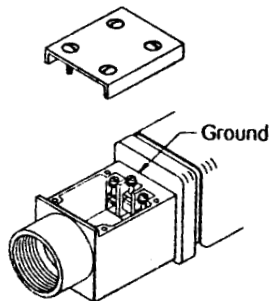

**Caution: The black matrix heating element is ELECTRICALLY CONDUCTIVE. It is not an insulator.**

## Start-Up Procedure...

When a WarmTrace system has been installed per this guide, start-up is easy. Simply follow the steps listed below. Please note that the operating current for the cable will be higher during start-up than during normal operating conditions. This is because the water in the heat traced piping is usually at the building's ambient temperature. This condition has been accounted for in the breaker sizing and circuit length tables provided so long as the ambient is at or above 15 C.

1. On the closed loop systems a valve or fixture should be partially opened to prevent excessive pressure accumulation as temperature rises.

2. Energize the heating cable and allow the system to reach its equilibrium temperature ( the building's water heater should be operating and the building's environment should be at an ambient temperature between 22 - 27 C).
3. The water heater/mixing valve which controls the water supply temperature should be set at the minimum storage temperature of 60° C (AS/ NZ Std 3500.4) do not exceed 65° C.
4. Using a calibrated thermometer check the water temperature at the water heater heater to be certain that it is within the desired range.
5. Again, using a calibrated thermometer check the water temperature at various fixture locations that are heat traced. Allow sufficient time for water to pass any unheated portion of water line.
6. Test for ground-fault protection by manually tripping the push-to-test button on the device (remember to reset after the test).

If start-up is not successful, refer to the Trouble Shooting section (pages 15-16) of this guide for assistance.



**Caution: Disconnect power to heating cable (turn off circuit breakers) during water heater start-up and hot water system purging if water temperatures will exceed 65 C.**

## Maintenance Checklist...

As part of an annual maintenance program or after any work ( repair or alterations) have been performed on or near the heat traced piping, the following steps should be performed.

1. Visually inspect the pipe's thermal insulation looking for any areas where the insulation has been removed, damaged or where the insulation appears repaired or replaced. Any suspect areas should be examined for damage to the heating cable. Verify that any new/repaired insulation meets the specification.
2. While inspecting the insulation, verify that it is completely dry. Wet insulation will not only cause temperature maintenance problems, but could also signal a more serious problem that could cause damage to the cable and the facility.
3. Test for ground fault protection by manually tripping the push-to-test button on the device (remember to reset after the test).

# WarmTrace™ Systems for Hot Water Temperature Maintenance

4. Using a calibrated thermomteter check the water temperature at the water heater to be certain that it is within the desired range. (refer maximum temperature settings page 13)
5. Again, using a calibrated thermometer check the water temperature at various fixtures locations that are heat traced. Allow sufficient time for water to pass any unheated portion of water line.
6. Heating cable should be tested with a megohmmeter (megger) at the power distribution panel by a qualified electrician (see page 11 for details on megger testing).
7. Record any observations on the projects's as-built drawings and any maintenance log kept for the facility (QC-3-Com)



**Caution: Do NOT enter any power connection point, cable splice or end termination while heating cable is energized. Disconnect power to heating cable and seek qualified assistance.**





# INSTALLATION INSTRUCTIONS

## Troubleshooting...

The following information is intended to assist in maintaining and troubleshooting a heat traced hot water supply system. The primary goal of a heat tracing system is to provide an efficient supply of hot water closer to the point of use than is possible with a recirculated system.

Like many other systems installed in a facility, the successful installation of a heat tracing system will require coordination among several trades involved in the construction process. Mechanical, electrical and insulation contractors must each provide services that are critical to the proper operation of the system.

Before calling your heat tracing vendor when things aren't going right, make a visual inspection; perhaps the thermal insulation is wet, damaged or missing. Also, consider the possibility that repairs or maintenance of nearby equipment may have resulted in damage to the heat tracing or its power supply. These are common causes of heat tracing problems, and they are often overlooked. A number of other possibilities are listed below, with their symptoms and remedies.

If at any time you feel that the heating cable has been damaged, a dielectric insulation resistance test with a megohmmeter (megger) is recommended. (See page 11 for test details.)

## Symptom - Water Not Hot Enough

Possible Causes...	Remedy...
1. Water heater/mixing valve set point too low.	Reset water heater temperature level, maximum temperature 65° C.
2. No power to heating cable	Check power distribution panel to ensure breakers are energized or have not tripped
3. Splice connection missed during installation	Using drawings and visual inspection, check to see if any splice connection has been overlooked. This may be evident if one area of a heat traced circuit is "cold".
4. Compressed, missing or wet insulation	Replaced missing or damaged insulation, ensure that pipe and insulation have not been forced against other pipes to cause heat sinks along it's length.
5. Pipes were not properly insulated	Ensure that insulation is per the table on page 11. Reinsulate where needed.
6. No heating cable installed in area	Verify that the pipe in question was scheduled for heating cable
7. Ambient temperature too low	Measure ambient temperature in intersitial space where the heat traced pipe is located. If the temperature is below 22 C for a 50 C or 60 C system (24 C for a 45 C system), the ambient is too cool. Raise the ambient temperature.
8. Cable not powered at correct voltage	Verify the proper design voltage and compare with measured value at power connection point.
9. Heat loss at temperature limiting valve	In some TLV's heat loss can occur between the hot and cold inlets via the non return valves. Check that dirt from system is not causing malfunction of the non return valves. Supply and install filter screens at inlets to valve body.

## Sympton - Water Too Hot

Possible Causes...	Remedy...
1. Water heater/mixing valve set point too high	Reset water heater temperature level, maximum temperature setting is 65° C
2. Pipes were not properly insulated	Ensure that insulation is per the table on page 11. Reinsulate where needed.
3. Ambient temperature too high	Measure ambient temperature in interstitial space where the heat traced pipe is located. If the temperature is above 27° C, the ambient is too high. Lower the temperature in the interstitial space.
4. Cable not powered at correct voltage	Verify the proper design voltage and compare with measured value at power connection point. Refer QC-3-Com fabrication sheet if available

## Sympton - Circuit Breaker Tripping

Possible Causes...	Remedy...
1. Improper electrical connection	Cable could be damaged or improperly connected. Visually inspect heating cable, connections and terminations. Test cable with megger.
2. Maximum circuit length exceeded	Verify the length of the heating cable, including all cable located on tee splices. Compare this metrage with the maximum circuit length and circuit breaker sizing chart located on page 7. Increase breaker size or add additional circuits if needed.
3. Piping/building is too cold during start-up	The building and the water in the pipe must be greater than 16° C. Raise building temperature or purge hot water lines.
4. Damaged power feed wire leading to power connection	Disconnect heating cable at power connection and test power feed wires running back to power distribution panel.
5. Faulty branch circuit breaker	Replace breaker and energize heating cable.



**Caution: Replace all damaged heating cable. Do not reconnect power to cable that has been exposed to excessive heat or moisture. Failure to replace damaged cable can cause arcing or fire.**



**Caution: Disconnect power to heating cable (turn off circuit breakers) when working on heat traced pipes, or heat tracing systems.**

