



PRODUCT DATASHEET

TRACENET™ ECM™

ELECTRONIC CONTROL MODULE

APPLICATION

The TraceNet ECM is an electronic control module specifically designed for controlling electric heat trace circuits used in freeze protection and temperature maintenance applications. The ECM serves both the temperature control as well as the sensor and power connection for a heat trace circuit.

The ECM is housed in a glass reinforced nonmetallic enclosure with an environmental protection rating of IP66. Depending on options selected, the ECM may be used as a combination temperature control and limiter, a temperature controller with either low or high temperature alarm, or a temperature limiter. Rotary switches are provided for adjusting temperature control and limiter set points. The standard version of the ECM communicates on a physical network of RS485 by using a Modbus RTU communication protocol.

The ECM is approved for use in both ordinary (non-classified) and hazardous (classified) areas.

The ECM-OS is available in a stainless steel junction box for use in offshore applications. (Refer to Form TEP0138)

RATINGS

Operating/control voltage.....120/208/240 Vac
 Operating ambient range..... -60°C to 55°C (-76°F to 131°F)
 Minimum ambient storage range -74°C (-100°F)
 Control switch type options..... SPST and DPST
 Switching current ratings¹
 SPST.....30/30/20 amps 25°C, 40°C, 55°C (77°F, 104°F, 131°F)
 DPST..... 28/23/17 amps 25°C, 40°C, 55°C (77°F, 104°F, 131°F)
 Alarm output current rating 2 A
 Electrical connection.....terminal blocks³
 Adjustable temp. control range.....
 0°C to 500°C (32°F to 932°F)
 Measurement range.....-60°C to 500°C (-76°F to 932°F)
 Measurement accuracy (ambient)
 ± 1°C (0°C to +55°C) ± 1.8°F (32°F to +131°F)
 ± 2°C (0°C to -60°C) ± 3.6°F (32°F to +131°F)
 Temperature sensor(s).....100 Ohm three wire Platinum
 RTD
 High temp. alarm/tripprogrammable
 (auto or manual reset)
 RTD input circuitry.....intrinsically safe (Ex i)
 Life expectancy.....250,000 cycles

CERTIFICATIONS/APPROVALS



II 2 G Ex eb mb [ib] IIC T4 Gb SIRA 12ATEX5239X
 II 2 D Ex tb IIIC T135°C IP66 Db



International Electrotechnical Commission
 IEC Certification Scheme for Explosive Atmospheres
 SIR 12.0103X



Class I Division 2, Groups A, B, C, D
 Class II Division 2, Groups F, G; Class III; T4
 14.2709489X Ex eb mb [ib] IIC T4
 Ex tb IIIC T135°C
 Class 1, Zone 1, AEx eb mb [ib] IIC T4
 Zone 21, AEx tb IIIC T135°C

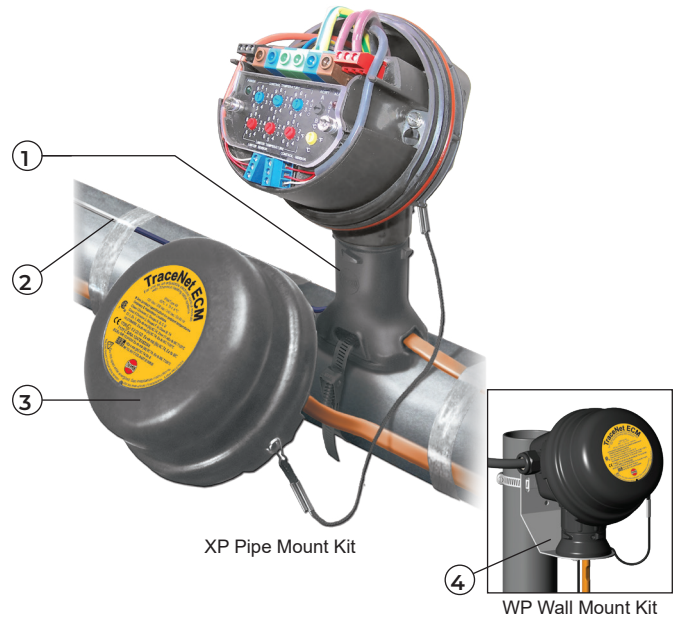

CONSTRUCTION

- 1 Pipe-mount expediter², glass-reinforced polymer
- 2 Three-wire RTD sensor (order separately)
- 3 Junction box, glass-reinforced polymer
- 4 316 Stainless Steel mounting bracket

PRODUCT FEATURES

- Encapsulated electronics and control
- One temperature control module for wide range of temperature control and limiter applications
- Energy saving accurate electronic temperature control action
- Data highway communication capability
- Selectable automatic or manual reset limiter action
- Control/limiter setting in degrees Centigrade or degrees Fahrenheit
- Combines power junction box and control module in one unit
- Also available as ambient thermostat (WP mount only)
- Refer to Form TEP0010, System Accessories - Heat Tracing Cables for additional accessories.

Notes

1. When located outdoors and subject to solar gain, some current de-rating will be required. Contact Thermon for additional information.
2. The pipe mount expediter has a maximum pipe exposure temperature of 482°F (250°C).
3. The terminal blocks consist of:
 - (6) 8 AWG line/load/PE terminals
 - (3) 12 AWG comm. port terminals
 - (3) 12 AWG alarm relay terminals
 - (2 x 3) 14 AWG sensor terminals
 See installation instructions for maximum wire size.



PRODUCT DATASHEET
TRACENET™ ECM™
 ELECTRONIC CONTROL MODULE

PRODUCT REFERENCE LEGEND

ECM-CL-12-P-XP-SP	
Control Type	Switch Configuration
C = Controller (with low temp alarm)	SP= Single Pole (120 Vac)
CH= Controller (with high temp alarm)	DP= Double Pole (208 or 240 Vac)
CL= Controller and Limiter	
Comm. Network	Mounting Options
1 = RS485	XP = Pipe-Mount Expediter
	WP = Wall Mount Bracket with Expediter
	Cable Profile
	P = RSX, VSX-HT, BSX, KSX, HTSX, FP, HPT, USX
	Nominal Voltage Range
	1 = 120 Vac
	2 = 240 Vac
	3 = 208 Vac

TYPICAL WIRING DIAGRAM (for controller with limiter)

Single Pole

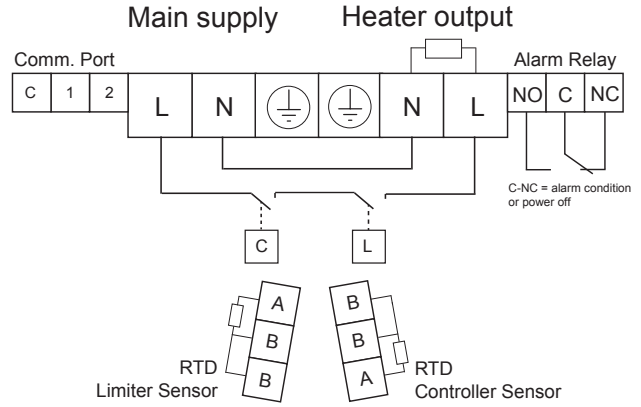

Double Pole

