

Electric Heat Tracing

INSTALLATION, MAINTENANCE,
& TROUBLESHOOTING

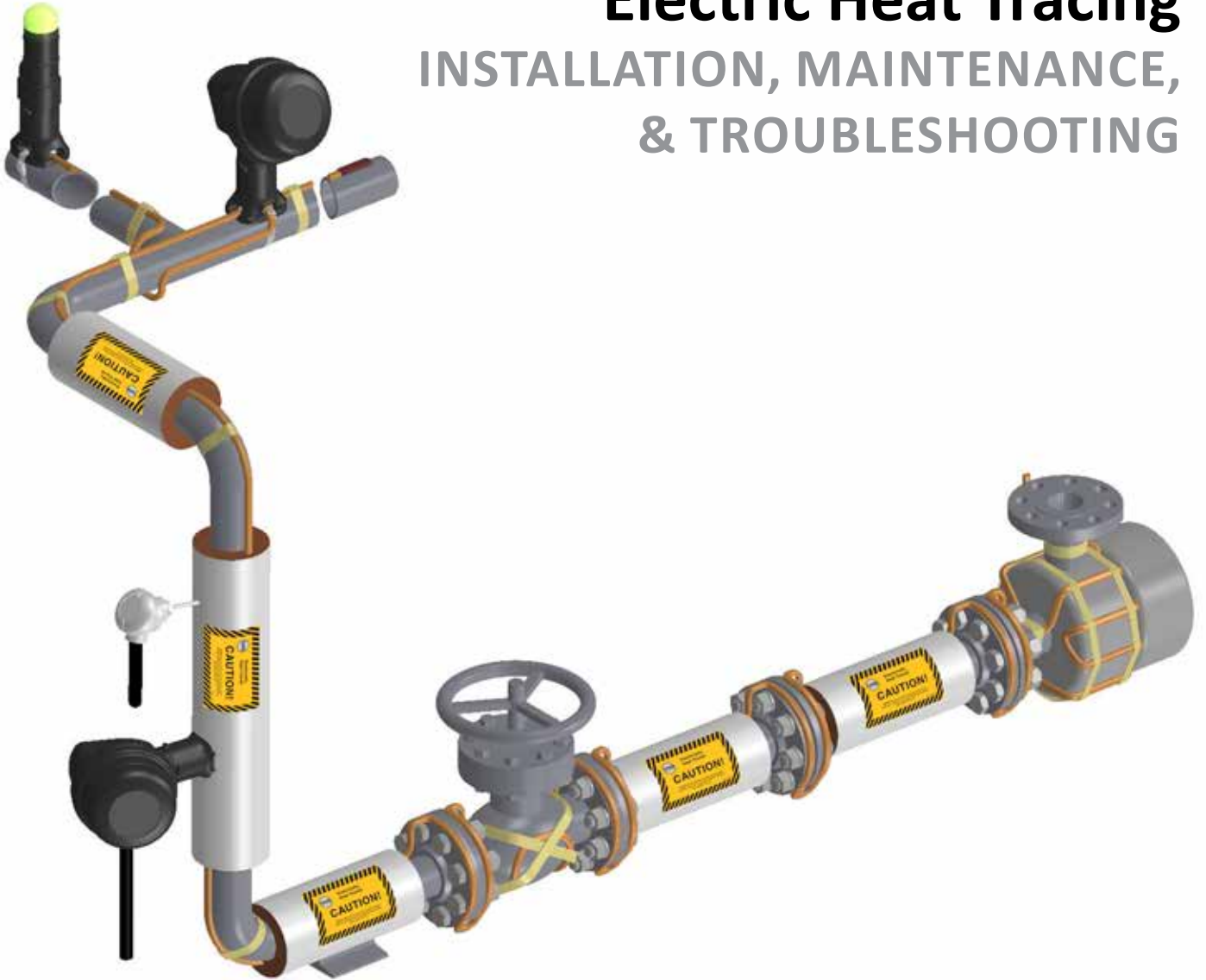

About These Instructions

The installation instructions within this document describe the installation of Thermon trace heating systems in typical piping applications and are suitable for use with the flexible trace heating products listed on page 4.

These instructions are not intended for mineral-insulated (MI) trace heaters. Instructions and documentation for other products and applications may be found at www.thermon.com.

For translations of this document in languages other than English, please contact Thermon. The English language version of this document shall govern.

IMPORTANT: To maintain warranty coverage of the trace heating system, the steps in these installation instructions, including testing, must be followed and documented on the Installation Report (page 12), wherever required in the text.

Safety and Site Practice

- Installation shall be carried out under the supervision of a qualified person.
- Persons involved in the installation and testing of electric trace heating systems shall be suitably trained in all special techniques required, including:
 - the purpose and function of the electrical trace heating system,
 - its associated power supply and control equipment, and
 - how to recognise and avoid the hazards associated with its operation and maintenance.
- All personnel shall use all appropriate personal protective equipment (PPE), including protective clothing, to protect against potential arc flash and shock hazards.
- All personnel shall comply with all applicable safety and health guidelines, including Thermon requirements, the regulations outlined in EN/IEC 60079-14 and EN/IEC/IEEE 60079-30-2 for hazardous areas (as applicable), and any other applicable national and local electric codes.
- During installation, the trace heating system parameters shall be verified. Tests shall be performed in the field **and documented in the Installation Report** (page 12) as instructed.

Thermon Flexible Polymer-Insulated Trace Heaters

Type ¹	Marking/Usage ^{1,6}	Minimum Installation Temp.	Minimum Bend Radius
Self-Regulating Trace Heaters			
BSX™	CE ₀₃₄₄ II 2 G Ex eb IIC T5 or T6, II 2 D Ex tb IIIC T100°C or T85°C SIRA 19ATEX3074 IECEX CSA 19.0009 Ex eb IIC T5 or T6, Ex tb IIIC T100°C or T85°C	-60 °C	10 mm @ -15 °C 32 mm @ -60 °C
RSX™ 2,3	CE ₀₃₄₄ II 2 G Ex eb IIC T6...120°C (T4), II 2 D Ex tb IIIC T80°C...T120°C KEMA 07ATEX0179 IECEX KEM 07.0052 Ex eb IIC T6...120°C (T4), Ex tb IIIC T80°C...T120°C	-50 °C	10 mm @ -15 °C 32 mm @ -50 °C
		With-FOJ option: -60 °C	10 mm @ -15 °C 32 mm @ -60 °C
HTSX™ 2,4	CE ₀₃₄₄ II 2 G Ex 60079-30-1 IIC T2 or T3 Gb, II 2 D Ex 60079-30-1 IIIC T300°C or T200°C Db FM 12ATEX0014X IECEX FMG 12.0004X Ex 60079-30-1 IIC T2...T3 Gb, Ex 60079-30-1 IIIC T300°C...T200°C Db	-60 °C	10 mm @ -15 °C 32 mm @ -60 °C
KSX™ 2,4	CE ₀₃₄₄ II 2 G Ex 60079-30-1 IIC T6...T3 Gb, II 2 D Ex 60079-30-1 T200°C...T85°C FM 07ATEX0027X IECEX FMG 06.0009X Ex 60079-30-1 IIC T6...T3 Gb, Ex 60079-30-1 T200°C...T85°C Db	-60 °C	10 mm @ -15 °C 32 mm @ -60 °C
USX™ 2,4	CE ₀₃₄₄ II 2 G Ex 60079-30-1 IIC T2 or T3 Gb, II 2 D Ex 60079-30-1 IIIC T300°C or T200°C Db CSANe 20ATEX3059 IECEX IECEX CSA 20.0006 Ex 60079-30-1 IIC T2...T3 Gb, Ex 60079-30-1 IIIC T300°C...T200°C Db	-60 °C	10 mm @ -15 °C 32 mm @ -60 °C
VSX-HT™	CE ₀₃₄₄ II 2 G Ex 60079-30-1 IIC T6...T2 Gb, II 2 D Ex 60079-30-1 IIIC T85°C...T300°C Db FM 18ATEX0009X IECEX FMG 18.0002X Ex 60079-30-1 IIC T6...T2 Gb, Ex 60079-30-1 IIIC T85°C...T300°C Db	-60 °C	10 mm @ -15 °C 32 mm @ -60 °C
Power-Limiting Trace Heaters			
HPT™ 5	CE ₀₃₄₄ II 2 G Ex 60079-30-1 IIC T6...T2 Gb, II 2 D Ex 60079-30-1 IIIC T85 °C...T300 °C Db DEKRA 16ATEX0093 IECEX DEK 16.0046 Ex 60079-30-1 IIC T6...T2 Gb, Ex 60079-30-1 IIIC T85°C...T300°C Db	-60 °C	10 mm @ -15 °C 32 mm @ -60 °C
Parallel Constant-Watt Trace Heaters			
FP	CE ₀₃₄₄ II 2 G Ex e II T3 to T6, II 2 D Ex tD A21 IP66/IP67 T200°C to T85°C FM 07ATEX0016 IECEX FMG 06.0008 Ex e II T3 to T6, Ex tD A21 IP66/IP67 T200°C to T85°C	-60 °C	10 mm @ -15 °C 19 mm @ -60 °C
Series Constant-Watt Trace Heaters			
HTEK™, TEK™	CE ₀₃₄₄ II 2 G Ex eb IIC T260°C (T2) to T6, Ex tb IIIC T260°C to T85°C FM 11ATEX0050 IECEX CCVE 11.0002 Ex eb IIC T260°C (T2) to T6, Ex tb IIIC T260°C to T85°C	-60 °C	22 mm @ -15 °C 32 mm @ -60 °C
TESH™	CE ₀₃₄₄ II 2 G Ex e IIC T2 to T6 Gb, II 2 D Ex tb IIIC IP6X T260°C to T80°C Db ISSeP 10ATEX015X	-60 °C	5 times the outside diameter

Notes

- Temperature ratings may vary within a trace heater product type. Always verify that the temperature ratings and markings of the trace heater are appropriate for the specific installation location.
- EN 60079-0, EN 60079-30-1, EN 60079-31, IEC 60079-0, IEC 60079-30-1, IEC 60079-31
- For use with integral components: TBX-3LC, ET-6C, PETK-1, SCTK-1, SK-SX, HS-PBSK-HD, and HS-ET-6C-HD. Also for use with other suitably certified connection kits such as Thermon Terminator series.
- For use with integral components: ET-8C, PETK-2, SCTK-2, TBX-4LC, and SK-SX. Also for use with other suitably certified connection kits such as Thermon Terminator series.
- For use with integral components: ET (-6C,-7C,-8C), TBX-4LC, PETK kits (-3,-3D,-4,-HPTXR), SCTK (-3,-3D,-4,-HPTXR), HPEK, and HPSK. Also for use with other suitably certified connection kits such as Thermon Terminator series.
- Specific conditions of use, for insulated externally heated surfaces, lower T- class systems may be obtained by utilizing stabilised design of a trace heating system using methods described in IEC/IEEE/EN 60079-30-1. Clause 4.5, using CompuTrace Electric Heat Tracing Design Software or by Thermon Engineering. The system design parameters, including the resulting T-class, shall be retained as a record of system documentation for each stabilised system design for as long as the system is in use. The parameters in the system documentation shall be checked during commissioning of the system.

About Electric Trace Heating Systems

Thermon electric trace heating systems are used for freeze protection or temperature maintenance of piping, tanks, and instrumentation. They may be installed in ordinary (nonclassified) and hazardous (classified) locations, depending on the specific trace heater options and approvals¹.

A typical self-regulating electric trace heating system (as depicted in Illustration A) may consist of the following components:

1. Electric trace heater (may be self-regulating, power-limiting, parallel constant-watt, or series constant-watt)¹.
2. Power connection kit².
3. RTD sensor or control thermostat².
4. In-line/T-splice kit (permitting two or three cables to be spliced together).
5. Cable end termination.
- 5a. End of circuit light kit.
6. Attachment tape (use on 30cm intervals, or as required by code or specification).
7. "Electric Heat Tracing- Caution" label.
8. Thermal insulation⁴ and vapor barrier.

The absence of any of these items can cause a system to malfunction or represent a safety hazard.

Notes

- 1 See Page 3 for trace heater types and approvals.
- 2 Power connections must be used with correctly-installed certified enclosures that are suitable for the application (such as Terminator™). When connecting Ex e certified terminals using associated accessories, the required creepage distances and clearances shall be observed.
- 3 Temperature control is recommended for all freeze-protection and temperature-maintenance trace heating applications.
- 4 All heat-traced lines must be thermally insulated.

Trace Heating System Design

- The design of electrical resistance trace heating systems shall be overseen by persons knowledgeable of trace heating, following the design methodology for explosive atmospheres as specified by Thermon Engineering or CompuTrace Electric Heat Tracing Design Software.
- For insulated externally heated surfaces, lower T-class systems may be obtained by utilizing stabilised designs or controlled designs using methods described in IEC/IEEE/EN 60079-30-1, Clause 4.5, using CompuTrace Electric Heat Tracing Design Software or by Thermon Engineering. The system design parameters, including the resulting T-class, shall be retained as a record of system documentation for each design for at least as long as the system is in use. The parameters in the system documentation shall be checked during commissioning of the system.
- The stabilised design method may be used for self-regulating, power-limiting, and constant-watt heating cables without a limiting device.
- Series heating cable output and T-rating are dependent upon several variables, including supply voltage, cable resistance, and temperature conditions.

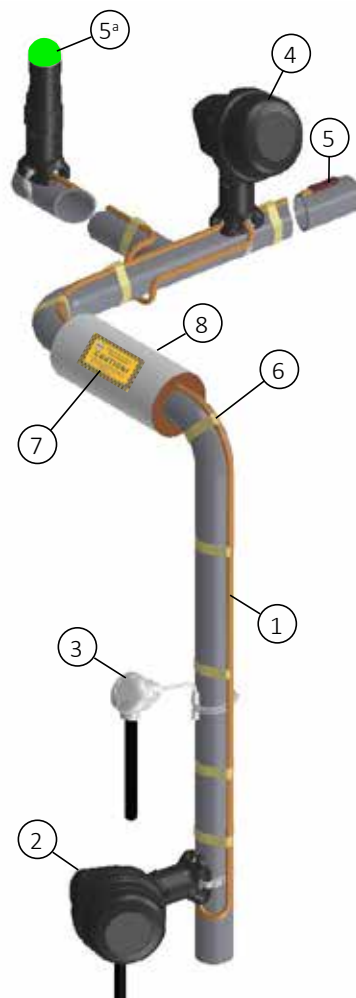

Illustration A: Typical Trace Heating Installation

Upon Receiving the Trace Heater

1. Make sure that the correct type (including the correct nominal power output and voltage level) has been received.

All flexible trace heaters, of the types covered in this document, are printed with the catalog number, voltage rating and power output (in W/m or W/ft) on the jacket. To verify the year of construction, please contact Thermon with the batch code number printed on the trace heater jacket.

2. **Record the reel number, reel length, trace heater type, and nominal power output and voltage in the Pre-Installation section of the Installation Report** (page 12).
3. Visually inspect cable for any damage incurred during shipment. **Note any observed damage** in the Installation Report.
4. Perform the Insulation Resistance (IR) Test, described on this page, to confirm the trace heater's electrical integrity. **Record the reading** in the Installation Report.
5. Store the trace heater in a dry location.

Before Installing

- Be sure all piping and equipment to be traced have been completely installed and pressure-tested.
- Ensure that all surface areas where the trace heater is to be installed are reasonably clean. Remove any dirt, rust, and scale with a wire brush. Remove oil and grease films with a suitable solvent.
- De-energise power sources before installation.
- Keep ends of trace heaters and kit components dry before and during the installation.

Insulation Resistance (IR) Testing

The insulation resistance (IR) test establishes the electrical integrity of the trace heater. For the flexible trace heaters covered in this document, the IR test should be performed with a megger capable of delivering a voltage of at least 500 Vdc.

1. If not done already, prepare the conductors of the trace heater according to the instructions accompanying the power and end termination kit(s) provided with the system.
2. Connect the megger's positive lead to the cable bus wires, shorted together.
3. Connect the megger's negative lead to the metallic braid.
4. Set the megger test voltage to 500 Vdc.
5. Energise the megger for 60 seconds.
6. Readings of at least 20 MΩ are acceptable.

Readings below 20 MΩ usually indicate that the electrical insulation of the trace heater has been compromised.

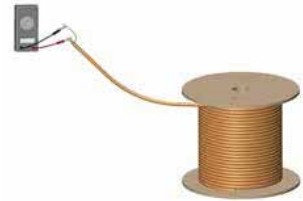

Check the trace heater for signs of physical damage between the braid and the heating element. Small cuts or scuffmarks on the outer jacket will not affect the megger reading unless there is penetration through the braid and dielectric insulation jacket.

Initial Trace Heater Installation

- Begin installing the trace heater at the proposed end-of-circuit location, following the guidance in the isometric system diagrams (if provided).
- Lay out the trace heater on the pipe, at the 4 or 8 o'clock position (Illustration B), securing it tightly against the pipe with attachment tape. Wrap bands of tape around the trace heater and pipe at intervals of 30 cm or less, keeping the trace heater in close contact with the pipe.
- If accessibility is a problem, the trace heater may be installed at the 10 or 2 o'clock position.
- Refer to Table 1 (page 8) to estimate the number of rolls of attachment tape required, based on the pipe length and diameter¹.
- A continuous covering of aluminum foil tape may also be required under special circumstances, including:
 - where spray or foam² thermal insulation will be applied,
 - where nonmetallic piping is used, or
 - design requirements dictate the use of aluminum tape.
- Allow extra length of trace heater for power connections, splices, and any in-line heat sinks (Illustration C). See page 8 and page 9 for details on how to properly install the trace heater at these sites and the allowance of trace heater required.
- Install temperature sensors at least 90° away from trace heater locations.
- **CAUTION:** For series constant-watt trace heaters (HTEK, TEK, TESH), do not allow the heating portion of the trace heater to touch, cross over, or overlap itself.
- **CAUTION:** Do not exceed the trace heater's specified minimum bend radius. Refer to page 4 of this document for the minimum bend radius of the specific trace heater type.

Notes

- 1 Table 1 assumes circumferential bands every 30 cm along the length of the piping.
- 2 Verify that the curing temperature of the insulation is less than the exposure temperature of the trace heater.

Illustration B: Heating Cable vs. Sensor Location

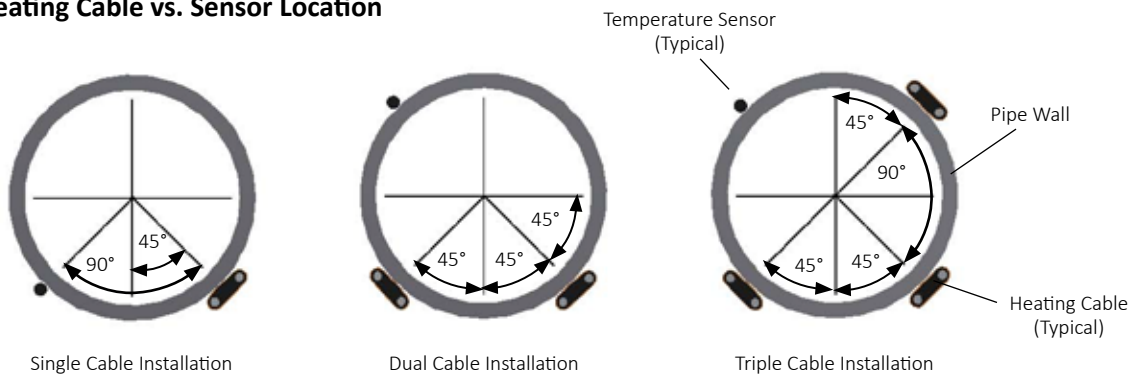

Illustration C: Temporary Installation

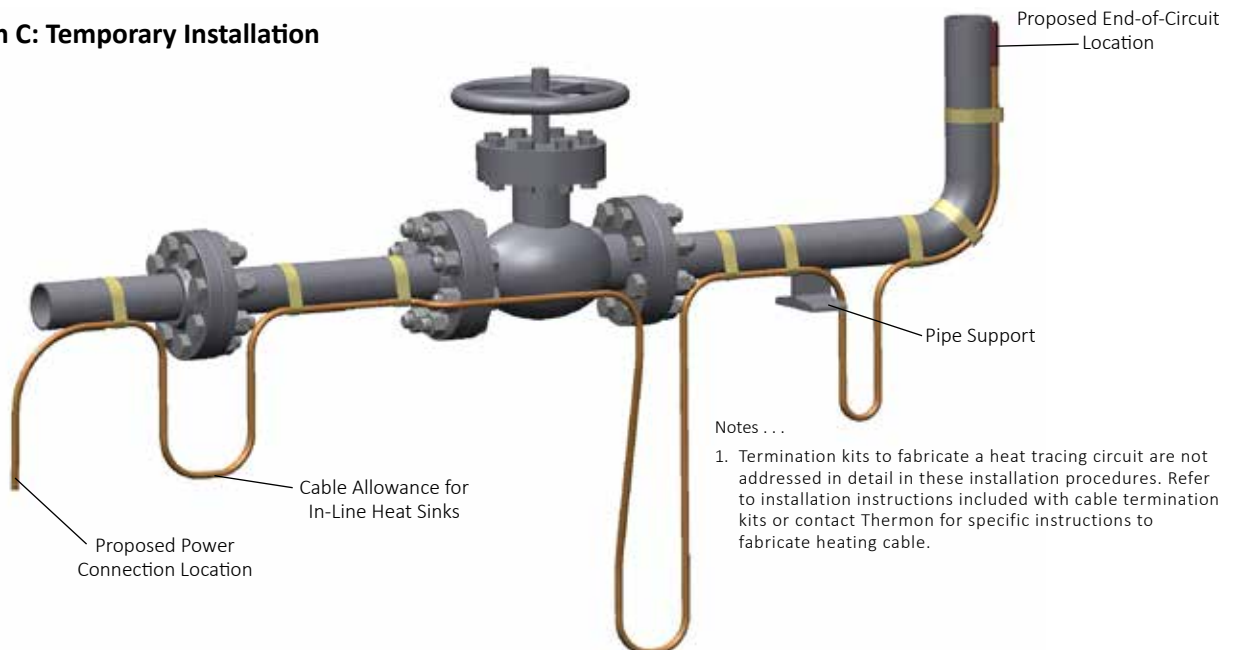

Table 1: Attachment Tape (Approximate Linear Pipe Length Allowance Per Roll)

Pipe Size mm	12-25	32	40	50	80	100	150	200	250	300	350	400	450	500	600	750
Length of Pipe/Roll of Tape m	109.7	79.2	67.0	54.9	45.7	36.6	27.4	21.3	18.2	15.2	12.2	10.7	9.1	7.6	6.0	4.6

Installation on Elbows, Pipe Supports, and Flanges

- **Elbows:** Locate the trace heater on the outside radius of the elbow (Illustration D). Secure the trace heater to the pipe with attachment tape on each side of the elbow.
- **Pipe Supports:** For uninsulated pipe supports, allow twice the length of the support, plus an additional 40 cm of trace heater. Install the trace heater in a loop, following Illustration E as a guide.

- **Flanges:** Loop the trace heater around the pipe on each side of, and adjacent to, the flange (Illustration F). Be sure to keep the trace heater in close contact with the flange throughout the length of the bend.

Refer to Table 2 (page 9) for typical flange allowances.

Insulated pipe supports do not require additional length of trace heater.

Illustration D: Pipe Elbow

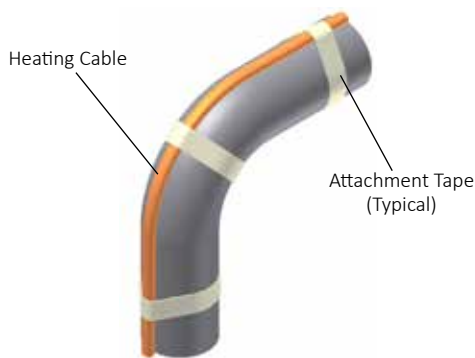

Illustration E: Uninsulated Pipe Support

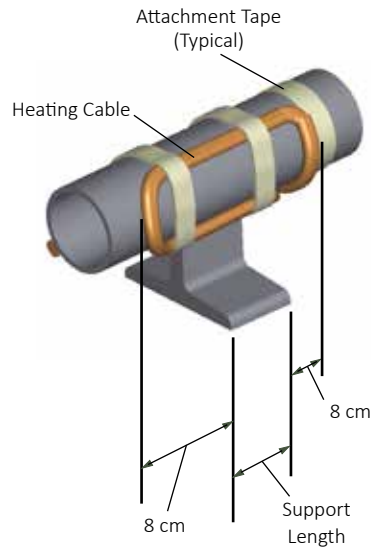
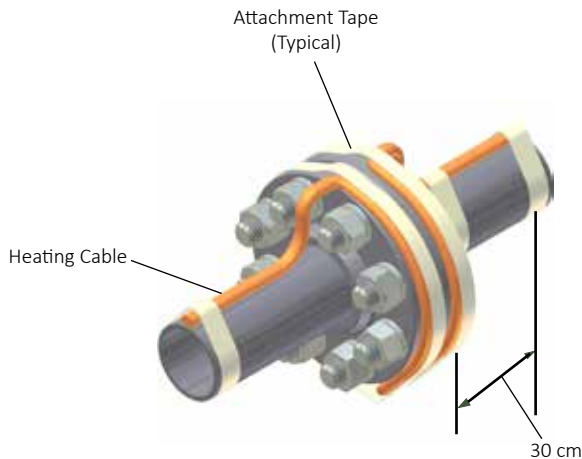

Illustration F: Pipe Flange



Note: Flange allowance will vary based on method of insulating flange and adjacent piping.



Circuit Layout on Support

Note . . .

1. Only applicable for pipe ≥ 50mm.

Installation on Valves and Pumps

- Valves, pumps, and other miscellaneous equipment require additional passes of trace heater to offset the increased heat loss that occurs at these sites.
- Refer to the isometric system drawings, provided by Thermon Engineering, for allowances specific to each line and circuit.

Allowances for typical valves and pumps are provided in Table 2.

- Install the trace heaters using a looping technique, using Illustrations G and H as a guide, such that the valve or pump may be removed for required service and maintenance.
- Keep the trace heater in close contact with the pipe and heat sink areas, to compensate for additional heat loss.

Table 2: Typical Valve, Pump, and Flange Allowances¹

Pipe Size (mm)	Valve Allowance (M)			Pump Allowance (M)		Flange Allowance (M)
	Screwed or Welded	Flanged	Butterfly	Screwed	Flanged	
12	0.20	0.30	0.00	0.30	0.61	0.38
20	0.20	0.46	0.00	0.46	0.91	0.46
25	0.30	0.61	0.30	0.61	1.22	0.46
32	0.50	0.61	0.30	0.91	1.37	0.61
40	0.50	0.76	0.46	0.91	1.52	0.61
50	0.60	0.76	0.61	1.22	1.68	0.69
80	0.80	1.07	0.76	1.52	2.13	0.69
100	1.20	1.52	0.91	2.44	3.05	0.84
150	2.10	2.44	1.07	4.27	4.88	0.99
200	2.90	3.35	1.22	5.79	6.71	1.14
250	3.80	4.27	1.22	7.62	8.53	1.30
300	4.60	5.03	1.52	9.14	10.06	1.52
350	5.50	5.94	1.68	10.97	11.89	1.68
400	6.60	7.01	1.83	13.11	14.02	1.83
450	7.80	8.23	1.98	15.54	16.46	1.98
500	8.70	9.14	2.13	17.37	18.29	2.21
550	10.40	10.97	2.44	20.73	21.95	2.51
600	12.20	12.80	3.05	24.38	25.60	3.05

¹ Allowance is the total length of additional trace heater to be installed. If multiple passes are used, total allowance may be divided among the individual passes.

Valve allowances are based on 150-pound class valves; more passes are required for higher-rated valves.

Illustration G: Typical Valve Detail

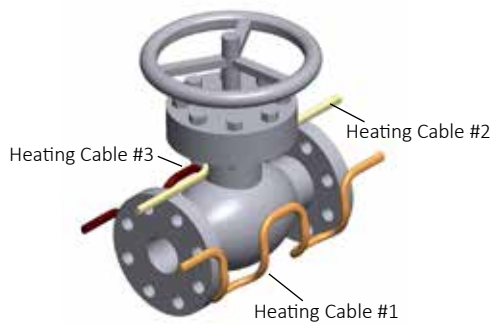

Heating Cable Serpentine on Valve

Illustration H: Typical Pump Detail

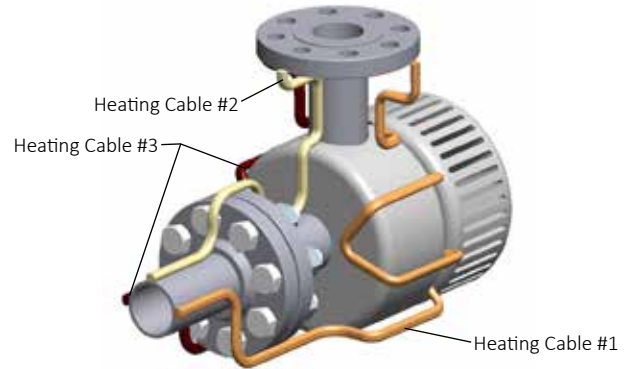

Heating Cable Serpentine on Pump

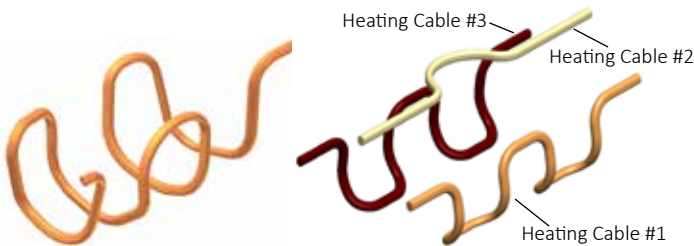

Single Circuit Layout on Valve

Multiple Circuit Layout on Valve ²

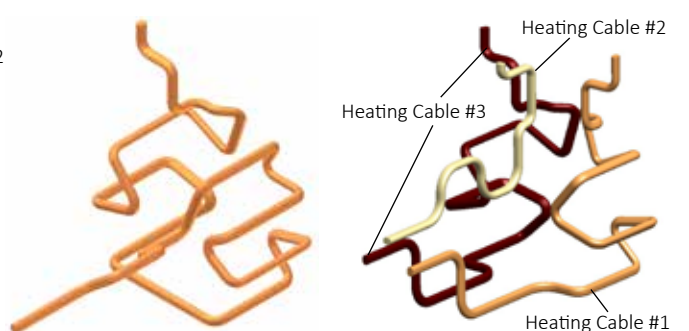

Single Circuit Layout on Pump

Multiple Circuit Layout on Pump ²

Completing the Trace Heater Installation

1. Secure the end-of-circuit termination kit and work back toward the power supply (Illustration I).
2. Keep the trace heater in secure contact with the pipe, using bands of attachment tape at least every 30 cm.
3. Secure any required temperature sensors to the pipe using attachment tape.
4. Complete any required splice connections in accordance with the installation instructions provided with the splice kit.
5. Install any power connection kits in accordance with the detailed installation instructions provided with the kit.
6. Connect the metallic braid of the trace heater to a suitable earthing/ground terminal.
7. Before completing the power connections, perform an Insulation Resistance (IR) Test (page 6) and **record the result in the After Installation** section of the Installation Report (page 12). The recorded value shall not be less than 20 MΩ.
8. **Record the line number and all other associated circuit information** in the After Installation section of the Installation Report.

Illustration I: Final Cable Attachment

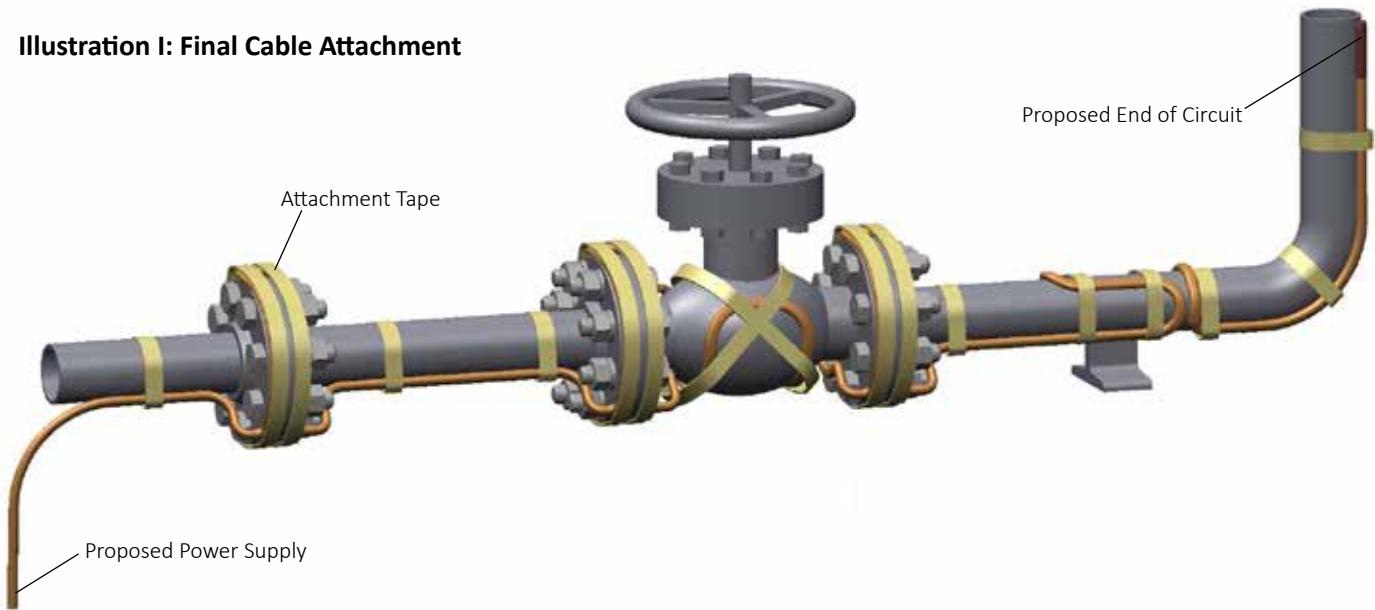

Installing Thermal Insulation

Properly installed and well-maintained thermal insulation is critical to the performance of the trace heating system. Without proper insulation, heat losses are generally too high to be offset by a conventional heat tracing system.

1. Properly insulate all heat sinks, including pipe supports, hangers, flanges, and in most cases, valve bonnets.
2. Install a protective vapor barrier over the insulation, regardless of the type or thickness of insulation used. The vapor barrier protects the insulation from moisture intrusion and physical damage and ensures the proper performance of the trace heating system.
3. Seal all penetrations around the vapor barrier.
4. After ensuring that the insulation is weather-tight, **document the completion of the insulation** in the After Installation of Thermal Insulation section of the Installation Report (page 12).

After Installing Thermal Insulation

The presence of trace heaters shall be made evident by posting of caution signs or markings at appropriate locations and/or at frequent intervals along the circuit.

1. Apply the provided peel-and-stick “Electric Heat Tracing- Caution” labels along the pipe, on the outermost surface of the thermal insulation or vapor barrier, at intervals of 3 m or less.
2. Apply the caution labels at any other appropriate locations, such as valves.

Circuit Protection Requirements

- Each branch circuit must use over-current protection that isolates all appropriate power conductors from the supply (typically circuit breakers).
- Earth fault equipment protection is required for each circuit.
- For typical installations (with TT and TN grounding systems), the means of protection must include a residual current protective device for each branch circuit.
- For fixed-level earth/ground-fault circuit interrupters, a minimum 30 mA trip level is recommended. The preferred trip level for adjustable devices is 30 mA above any inherent capacitive leakage characteristic of the heater, as specified by Thermon Engineering.
- Where conditions of maintenance and supervision ensure that only qualified persons will service the installed systems, and continued circuit operation is necessary for the safe operation of the equipment or processes, earth-fault detection without interruption is acceptable if alarmed in a manner to assure an acknowledged response.
- For IT grounding systems, a means of protection against earth faults is required that includes an electrical insulation monitoring device that shall disconnect the supply whenever the electrical resistance is not greater than 50 ohms/volt of rated voltage.

Final Inspection

1. After installing the thermal insulation and vapor barrier **BUT BEFORE ENERGIZING THE CIRCUIT**, repeat the IR test to verify that the trace heater has not been damaged during installation. **Record the IR value** in the After Installation of Thermal Insulation section of the Installation Report (page 12).
2. For Series Heating Cables, measure the electric loop resistance and **record the resistance values** in the Installation Report.
3. Ensure that all junction boxes, temperature controllers, cable glands, etc., are properly secured.
4. If a temperature controller is used, force the circuit on and energise the circuit at the rated voltage.
5. After 5 minutes, measure the voltage, current, pipe temperature, and ambient temperature. **Record these values in the Final Commissioning section of the Installation Report.**
6. If a control device is used, verify its settings to ensure that the maximum surface temperature does not exceed the system T-rating, in accordance with IEC/IEEE/EN 60079-30-1, Clause 4.

Documentation Retention

The trace heating system documentation shall be retained for each trace heating circuit for as long as the system is in use. This includes:

- System Design Parameters And T-Class
- Isometric Circuit Diagrams
- Maintenance Records
- Operating History
- These Instructions
- All Other Documentation Provided By Thermon

Installation Report

Project Information			
Project No.		Installer	
Unit No.			
Customer Reference No.		Inspector	
Thermon Reference No.			
Pre-Installation			
Reel No.		Insulation Resistance (IR)	
Reel Length	m/ft	Single-Phase:	MΩ/GΩ
Trace Heater Type		3-Phase	L_1 MΩ/GΩ
Power Output (nom.)	W/m/W/ft	(for Series	L_2 MΩ/GΩ
Voltage (nom.)	V	Trace Heaters):	L_3 MΩ/GΩ
Notes	Tested By/Date		
	Witnessed By/Date		
After Installation			
Line No.		Braid Connected to Ground?	
Equipment No.		Unused Entries Plugged Off?	
Circuit/Heater No.		Insulation Resistance (IR)	
Circuit Switch No.		Single-Phase:	MΩ/GΩ
Thermostat No.		3-Phase	L_1 MΩ/GΩ
Junction Box No.		(for Series	L_2 MΩ/GΩ
Panel No.		Trace Heaters):	L_3 MΩ/GΩ
Breaker No.			
Trace Heater Line Length	m/ft		
Notes	Tested By/Date		
	Witnessed By/Date		
After Installation of Thermal Insulation			
Insulation Weather-Tight?		Insulation Resistance (IR)	
Caution Labels Placed?		Single-Phase:	MΩ/GΩ
Electrical Loop Resistance (for Series Trace Heaters)	$L-L$	Ω	3-Phase
	L_1-L_2	Ω	(for Series
	L_2-L_3	Ω	Trace Heaters):
	L_3-L_1	Ω	
Notes	Tested By/Date		
	Witnessed By/Date		
Final Commissioning			
Perform final measurements after energising circuit for 5 minutes.			
Ambient Temperature	°C/°F	Voltage	V
Pipe Temperature	°C/°F	Current	A
Notes	Tested By/Date		
	Witnessed By/Date		

NOTE: All Insulation Resistance (IR) values shall be at least 20 MΩ for a successful installation.

Maintenance and Repair

- Once the system has been successfully installed, an ongoing preventive maintenance program should be implemented, using qualified personnel. The trace heating system should be inspected and tested on a regular basis, at least once per year.
- Keep records of the operating and maintenance history for each circuit, including all test results performed during maintenance and inspection. Record-keeping during scheduled maintenance will help to establish a “normal” range of operation. Insulation resistance readings that deviate from the normal range may indicate problems with a circuit.
- If the system fails any test, refer to the troubleshooting guide below to address the issue. De-energise the affected circuits and make the necessary repairs immediately.

Before maintenance, repair, or modification

CAUTION: Consult the trace heating system documentation prior to maintenance, repair, or modification.

1. Identify the circuit or equipment to be de-energised and all possible sources of electrical energy supplies to the specific circuit and equipment.
2. De-energise all power sources.
3. Apply lockout/tagout devices according to established procedures.
4. Test for the absence of voltage with an approved voltmeter (where the voltmeter is tested on a known circuit voltage prior to and immediately following application).
5. For protection against the accidental energizing of supply conductors, apply temporary jumpers rated for the available fault duty between each supply conductor and earth/ground.

NOTE: In the event of an earth fault or over-current interruption, devices shall not be reset until the cause of the trip has been investigated by qualified personnel.

After maintenance, repair, or modification

1. Test the operation of each affected circuit.
2. The insulation resistance of the trace heater shall be measured and recorded and shall not be less than 20 MΩ.
3. Visually verify that all circuit-disconnect devices are open before reconnecting power.

Troubleshooting Guide

This troubleshooting guide aims to help to diagnose and resolve many issues on-site.

Many problems with electric trace heating systems can be attributed to two causes:

- Wet, damaged, or missing insulation. Visually inspect the insulation along the entire length of the circuit, making sure that it is intact and dry throughout.

- Physical damage incurred from recent repairs and maintenance to any in-line or nearby equipment.

Other possible causes are listed below, with their symptoms and potential remedies.

If any circuit is suspected to be damaged, de-energise the circuit and perform the Insulation Resistance Test outlined on page 6. Readings below 20 MΩ indicate that the trace heater may be physically damaged.

Symptom	Possible Cause	Remedy
No heat/no current	• Loss of power/voltage	• Check the circuit breaker and electrical connections
	• Controller setpoint too low	• Verify/adjust setpoint
	• High-temperature limit switch activated	• May require manual reset to re-enable trace heating circuit
	• “Open” series heating circuit	• Repair or replace circuit ¹
	• Controller failure	• Repair sensor or controller ²

Symptom	Possible Cause	Remedy
Low system temperature	• Controller setpoint too low	• Verify/adjust setpoint
	• Temperature sensor located too close to trace heater or other heat source; may be accompanied by excessive cycling of control relays/contacts	• Relocate sensor
	• Insulation material and/or thickness different than designed	• Replace insulation; increase insulation thickness (if dry); review design ³
	• Ambient temperature lower than designed	• Install higher-output trace heater; increase insulation thickness; review design ³
	• Low voltage (check at power connection point)	• Adjust voltage to meet design requirements ³
Low temperature in sections	• Wet, damaged, or missing insulation	• Repair or replace insulation and barrier
	• Trace heater damaged	• Repair or replace section; splice kits are available from Thermon
	• Heat sinks (valves, pumps, pipe supports, etc.)	• Insulate heat sinks or increase passes of tracing on heat sinks
	• Significant changes in elevation along length of the heat-traced pipe	• Consider dividing heating circuit into separate, independently controlled segments
High system temperature	• Controller “on” continuously	• Adjust setpoint or replace sensor ²
	• Controller fails with contacts closed	• Replace sensor or controller ²
	• Sensor located on uninsulated pipe or too close to heatsink	• Relocate sensor to an area representative of conditions along length of pipe
	• Backup heating circuit controller “on” continuously	• Adjust setpoint or replace backup controller
Excessive cycling	• Temperature sensor located too close to trace heater or other heat source; may be accompanied by low system temperature	• Relocate sensor
	• Ambient temperature near controller setpoint	• Temporarily alter controller setpoint
	• Connected voltage too high	• Lower voltage
	• Trace heater output too high (overdesign)	• Install lower-output trace heater or lower the voltage
	• Controller differential too narrow	• Widen the differential or replace controller to avoid premature contact failure
Temperature variations along pipe	• Inconsistent trace heater installation along pipe	• Check consistency of trace heater installation, especially at heat sinks
	• Inconsistent trace heater performance	• Compare calculated power per unit length ($W \times A/\text{length}$) for the measured pipe temperature with designed trace heater output for the same temperature; regional damage to trace heater can cause partial failure
	• Unanticipated flow patterns or process operating temperatures	• Redistribute heating circuits to accommodate existing flow patterns; confirm process conditions

Notes

- 1 Flexible, polymer-jacketed trace heaters (such as those covered in this document) may be field-spliced. Mineral-insulated (MI) trace heaters typically require replacement.
- 2 Mechanical thermostat sensors cannot be repaired or replaced. RTD and thermocouple sensors may be replaced. Some controllers have replaceable contacts/relays or may require a manual reset if a “trip-off” condition was detected.
- 3 Before making any changes to system parameters, consult Thermon for the impact on trace heater performance.



tce Thermal Controls
and Electronics

TC-E B.V.
Nieuwland Parc 314c
2952 DD Alblasterdam
The Netherlands

+31 (0) 183 20 10 88
sales@tc-e.nl
www.tc-e.nl - www.heattrace.eu
Authorized Thermon distributor