

ECM-OS

Electronic Control Module

INSTALLATION PROCEDURES

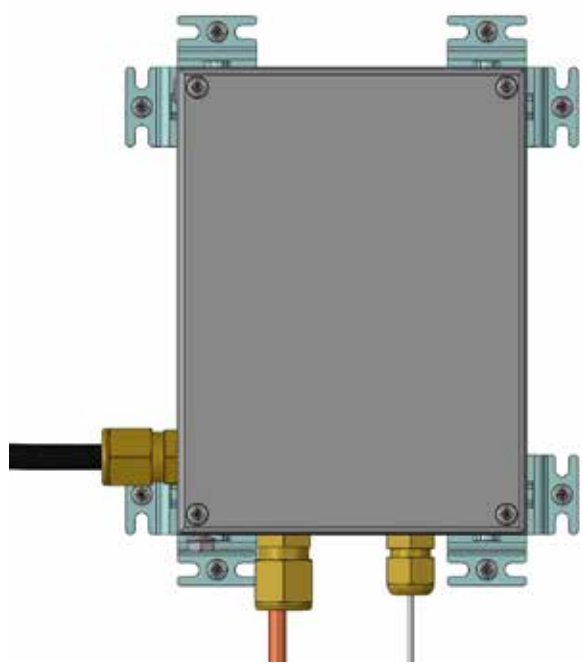

The Heat Tracing Specialists®

ECM-OS

The following installation procedures are suggested guidelines for the installation of the ECM-OS Kit. For translations other than English and local language translation provided here, please contact Thermon. The English language installation procedure shall govern.

Receiving, Storing and Handling . . .

1. Inspect materials for damage incurred during shipping.
2. Report damages to the carrier for settlement.
3. Identify parts against the packing list to ensure the proper type and quantity has been received.
4. Store in a dry location.

Kit Contents . . .

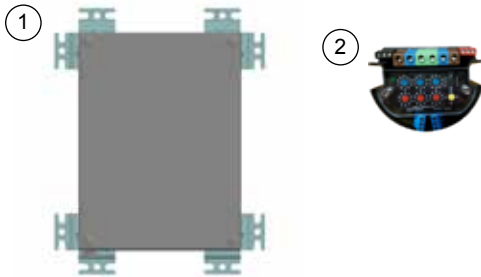

Item	Quantity	Description
1	1	Stainless Steel Junction Box
2	1	Electronic Control Module w/ Terminal Blocks (Refer to terminal specifications for maximum allowable wire size) ECM Type* C - Controller L - Limiter CL - Controller/Limiter * The maximum pipe exposure temperature is limited to 232°C

Order Separately . . .

- 1 Power Gland
 - 2 Heating Cable
 - 3 RTD
-

PETK Power and End Termination Kits (per cable)

- PETK-1 for RSX, VSX, BSX
 PETK-2 for KSX, HTSX
 PETK-3-ECM for HPT, FP

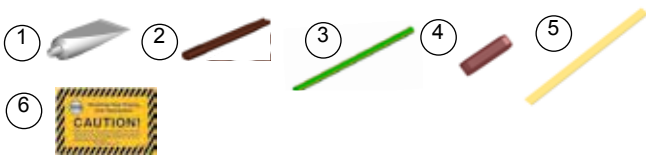

Item	Quantity	Description
1	1	RTV Tube
2	1	Power Connection Boot
3	2	Ground Sleeve
4	1	End Cap
5	1	Tape Strip (PETK-3-ECM only)
6	1	End Termination Caution Label

INSTALLATION PROCEDURES

Order Separately . . .

IEK Insulation Entry Kit (per cable)

- IEK-SXL: for RSX, VSX,
 IEK-SXM for BSX
 IEK-SXS for KSX, HTSX
 IEK-HPT for HPT
 IEK-RTD for RTD Lead Wire



Dimensions . . .

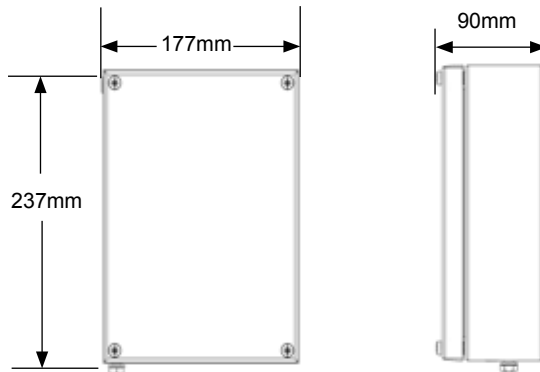

Warnings . . .

- Due to the risk of electrical shock, arcing and fire caused by product damage or improper usage, installation or maintenance, a ground-fault protection device is required.
- Installation must comply with Thermon requirements (including form PN 50273U for Ex systems) and be installed in accordance with the regulations as per the norm EN IEC 60079-14 for hazardous areas (where applicable), or any other applicable national and local codes.
- Component approvals and performance ratings are based on the use of Thermon specified parts only.
- Only appropriate Ex certified glands, blanks and adaptors with a degree of protection of IP66 or better may be used.
- De-energize all power sources before opening enclosure.
- Avoid electrostatic charge. Clean only with a damp cloth.
- Keep ends of heating cable and kit components dry before and during installation.
- Minimum bending radius of heating cable is 32 mm (except HPT is 57 mm and FP is 19 mm).
- Individuals installing these products are responsible for complying with all applicable safety and health guidelines. Proper Personal Protective Equipment (PPE) should be utilized during installation. Contact Thermon if you have any additional questions.

Tools Required . . .



Certifications/Approvals . . .

CE Ex II 2 (2) G Ex eb mb [ib] IIC T4, Ex tb IIIC T135°C SIRA 12ATEX5239X
 II 2 (2) D Ex tb IIIC T135°C IP66 Db

IEC IECEx International Electrotechnical Commission
 IEC Certification Scheme for Explosive Atmospheres
 SIR 12.0103X

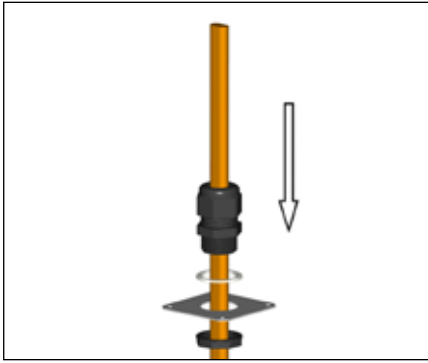

1. Slide appropriate IEK insulation entry kit components onto cable.

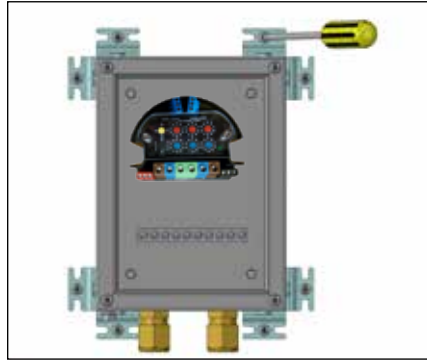

2. Mounting: Secure wall mount to mounting surface using screws (provided by others).

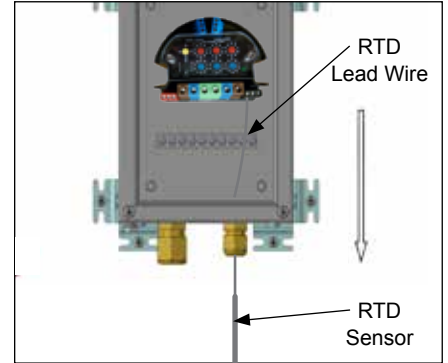

3. Position RTD Sensor(s) in grommet. Do not pull from the sensor end when routing through the RTD gland. Pull sensor from the lead wire portion.

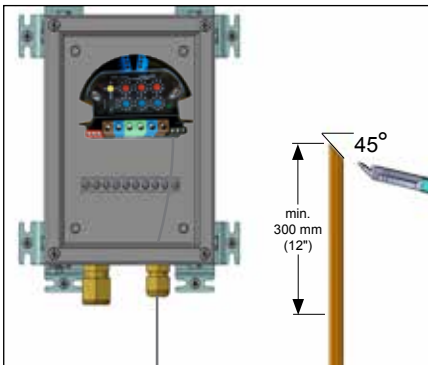

4. Locate bus connection (HPT and FP only) as shown. Cut end of cable at angle to aid in piercing grommet. Leave additional cable for expansion as needed.

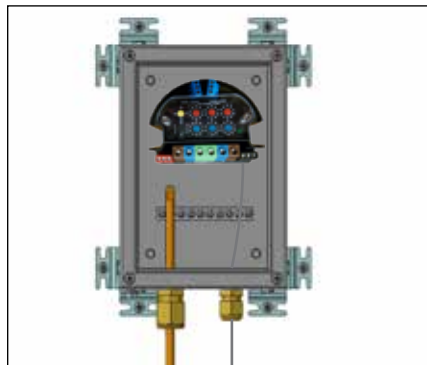

5. Insert cable into gland. Make sure bus connection (HPT and FP only) remains outside of expediter.

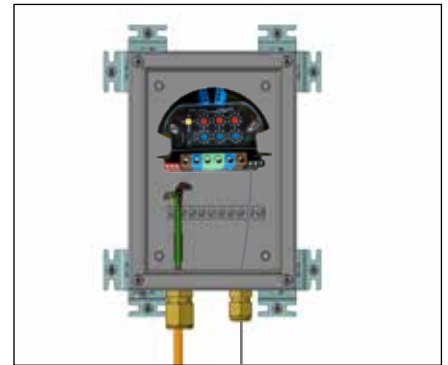

6. Terminate cable with appropriate PETK termination kit. Refer to PETK installation instructions. Push excess cable back through gland. Tighten cap securely. Tape cable expansion loop to pipe.

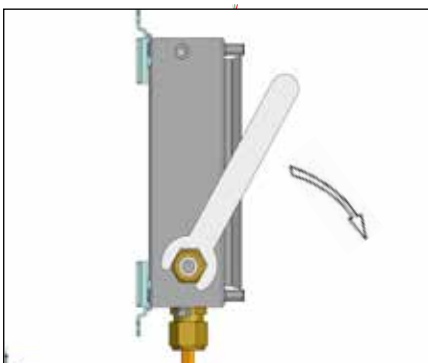

7. Install M25 power gland (order separately) and M25 blind plug.

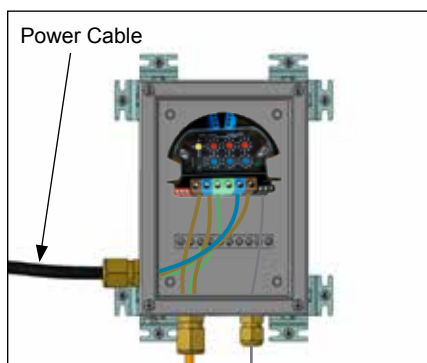

8. Install power cable. Complete system wiring. Terminal set screws shall be tightened to a torque value of 1,4 Nm (12,4 lb-in). See wiring details. Set modules electronic control and/or control limiter at desired setpoints.

Wiring Details

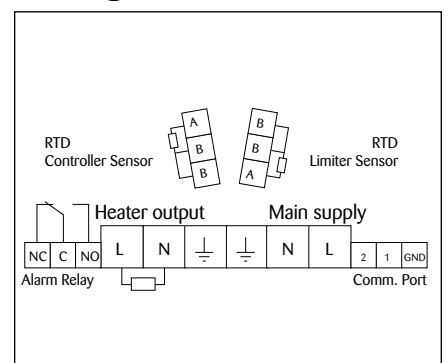

9. Wiring Details: Connect ground wire from power cable, braid from heater, and connections from the module to the grounding strip.



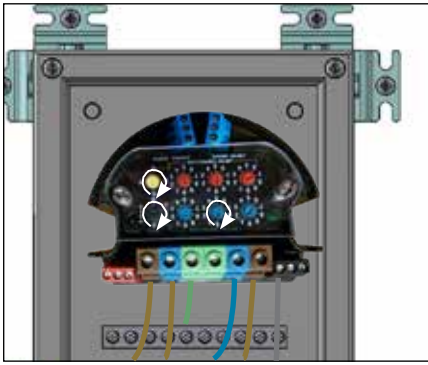

10. Use the rotary switches for setting Control and Limit Temperature, (Celsius or Fahrenheit) and Auto or Manual reset (Control switches on Type "C", Limiter switches on Type "L" and both on Type "CL").

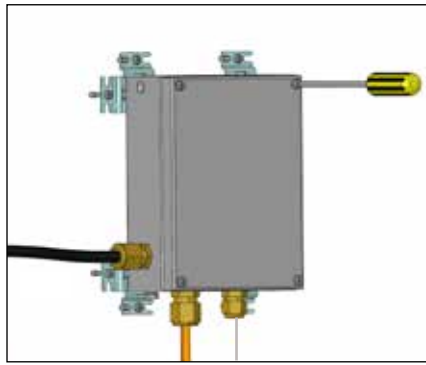

11. Install junction box lid using mounting screws provided.

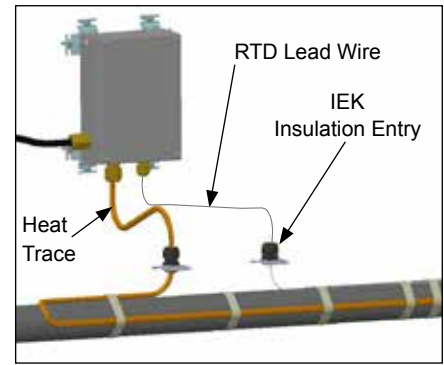

12. Slide IEK insulation entry kit onto RTD lead wire. Fix RTD lead wire and sensor to pipe.

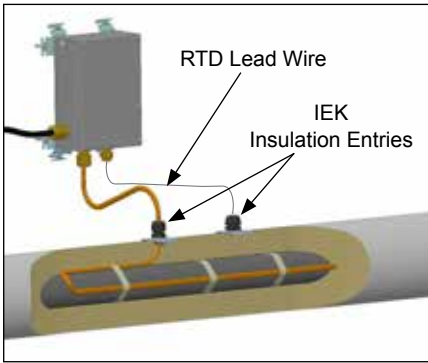

13. Install IEK insulation entry kit to seal heating cable and RTD lead wire penetrations through insulation cladding.



THERMON . . . The Heat Tracing Specialists®
For the Thermon office nearest you visit us at . . . www.thermon.com

For Access To Installation Videos:

ISO 9001
REGISTERED

tce Thermal Controls
and Electronics

TC-E B.V.
Nieuwland Parc 314c
2952 DD Alblasserdam
The Netherlands

+31 (0) 183 20 10 88
sales@tc-e.nl
www.tc-e.nl - www.heattrace.eu
Authorized Thermon distributor