

ThermoTube[®] Type SL

INSTALLATION PROCEDURES

(Steam Tracing Only)



The Heat Tracing Specialists[®]

ThermoTube® Type SL

The following installation procedures are suggested guidelines for the installation and support of ThermoTube preinsulated steam supply and condensate return tubing. They are not intended to preclude the use of other methods and good engineering or field construction practices.

Receiving, Storing and Handling . . .

1. Inspect materials for damage incurred during shipping. Report damages to the carrier for settlement.
2. Identify the ThermoTube type to ensure the proper material and quantity has been received. Boxes and reels are marked on the outside with the ThermoTube part number, length, product description, weight and customer purchase order number. Compare information on box or reel with packing slip and purchase order to verify receipt of correct shipment.
 - Lengths shorter than 25 m are shipped in heavyweight cardboard boxes.
 - Lengths greater than 25 m are shipped on nonreturnable wooden reels.
3. The ends of ThermoTube are factory-sealed to prevent dirt, moisture and insect intrusion. As a preventive measure, keep ends sealed until final connections are made. Cut ends may be temporarily sealed with plastic wrap and tape.
4. Cardboard boxes and wooden reels of product should be stored indoors away from standing water. However, wooden reels may be stored outdoors using a protective covering.
5. ThermoTube is shipped with the end of the tubing strapped to the side of the wooden reel. Use caution when releasing the end of the tubing from the reel as it is under tension and may recoil when released.

Tubing Layout . . .

1. Determine lengths and number of fittings prior to uncoiling ThermoTube since uncoiling and recoiling will “work harden” the tubing.
2. Position reel such that ThermoTube may be pulled from the reel toward the least accessible end point allowing installation to begin at the end point working back toward the reel.
3. To uncoil and straighten ThermoTube, anchor the loose end of the tubing on a flat surface and roll the hand coil or shipping reel. If additional straightening is needed, apply tension to the tube.

4. Wooden spools of ThermoTube containing long lengths of tubing can be placed on a pay-off tray as shown in Illustration A below. To “pay-off” ThermoTube, place the reel containing the tubing on one tray allowing the tubing to freely spool from the bottom of the reel.
5. Straighten ThermoTube by utilizing a counterspool located in front of the reel containing the tubing (see Illustration A). The counterspool should be located at a distance of 2½ times the diameter of the ThermoTube reel. Include a vertical offset of 200 to 250 mm between the reel centers.

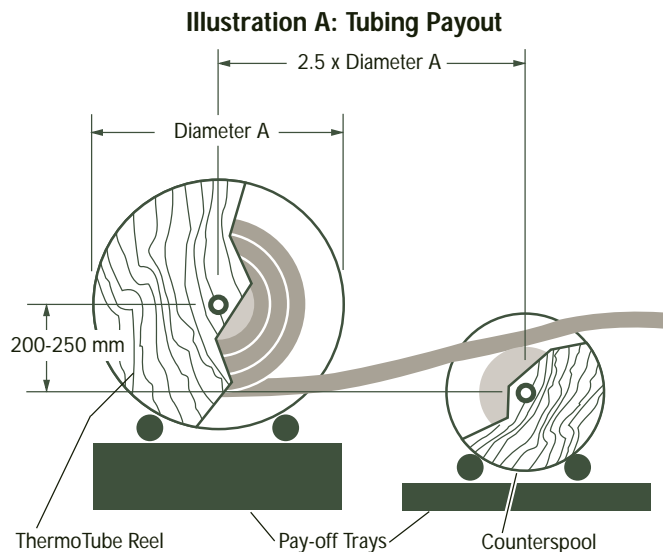

Bending Procedure . . .

1. ThermoTube must be bent so there is no strain on the fitting after the tubing is installed. The cross-sectional area of ThermoTube should not be flattened, kinked or wrinkled. Refer to Table 1 for the minimum acceptable bending radius for each ThermoTube type. Use a properly sized conduit bender or mechanical tubing bender to assure constant radius bends where possible.

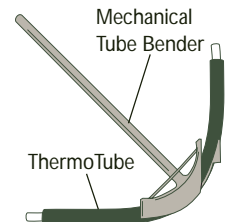

| Tube Dia. O.D. mm | ThermoTube O.D. mm | Min. Bend Radius ² mm | Recommended Conduit Strap Size |
|-------------------|--------------------|----------------------------------|--------------------------------|
| 1/4 (6) | 1.15 (29) | 178 | 20 mm Rigid |
| 3/8 (10) | 1.25 (32) | 178 | 50 mm EMT |
| 1/2 (12) | 1.35 (34) | 203 | 50 mm Rigid |
| 3/4 (19) | 1.8 (46) | 254 | 40 mm EMT |

Notes . . .

1. Make bends with a mechanical tubing bender. Other types of benders can also be used if care is taken to prevent deforming or flattening of the tube.
2. The bending radius for each ThermoTube type is based on the outside diameter of the protective jacket.



The Heat Tracing Specialists®

INSTALLATION PROCEDURES

Tubing Installation . . .

1. For ease of installation and maintenance, route multiple runs of ThermoTube symmetrically utilizing the most accessible path possible. Routing should take advantage of existing cable trays, angles, channels, struts and I-beams for support. Maintain a 12 mm minimum clearance between lines (see Illustration B).
2. ThermoTube must maintain a 20 mm per metre minimum slope toward the tracer, supply station or condensate return header to avoid trapping water during shutdown periods.
3. Secure ThermoTube to support structure every 1.5 to 1.8 m on horizontal straight runs and every 3 to 4.5 m on vertical runs. Provide additional support within 450 mm of any connection point or transition fitting and within 150 to 250 mm of any bends.
4. Cable trays and channel struts provide optimal support for multiple passes of ThermoTube. Secure ThermoTube to cable tray using UV resistant plastic cable ties, or preferably stainless steel banding, while utilizing cable clamps or standard conduit straps for channel strut attachment (see Table 1 for conduit strap sizing). Use caution when securing ThermoTube to structure. Do not crush the thermal insulation and outer jacket.
5. As an option, angle iron may be used to support ThermoTube on long vertical and horizontal runs. Angle iron should be sized approximately 12 mm larger than the tubing O.D. Place the angle over the ThermoTube to prevent moisture buildup. Secure ThermoTube to the angle using

UV resistant cable ties or stainless steel banding, as outlined in step 3 of the tubing installation.

6. Contact factory to obtain recommended maximum ThermoTube lengths relative to steam pressure.
7. A time proven empirical method used by Thermon is to limit the accumulated vertical rise "AVTR" in bar g, to 0.666 of the inlet steam pressure. For example, using a steam pressure of 10.35 bar g X 0.666, the AVTR would be approximately 6.89 m.

Inspection of System . . .

1. Verify that ThermoTube is properly secured to the support structure without causing deformation to the insulation and outer jacket.
2. Thoroughly inspect ThermoTube after installation is complete to ensure all bends are free of kinks and wrinkles and that flattening has not occurred. Refer to the bending guidelines on page 1 of these installation procedures.
3. Properly terminate and seal all open ends of ThermoTube using the FAK-7 end seal kit and FAK-8 patch kit. Refer to the illustrations on page 3.
4. Clean the tubing before connection. After all connections to the steam tracers, supply header and collection manifolds have been completed, test the circuit for leaks by subjecting it to steam pressure equal to or greater than that which is to be used in the system, or preferably with suitable hydrostatic tests. Repair any leaks and retest the system.

Illustration B: Typical ThermoTube Installation

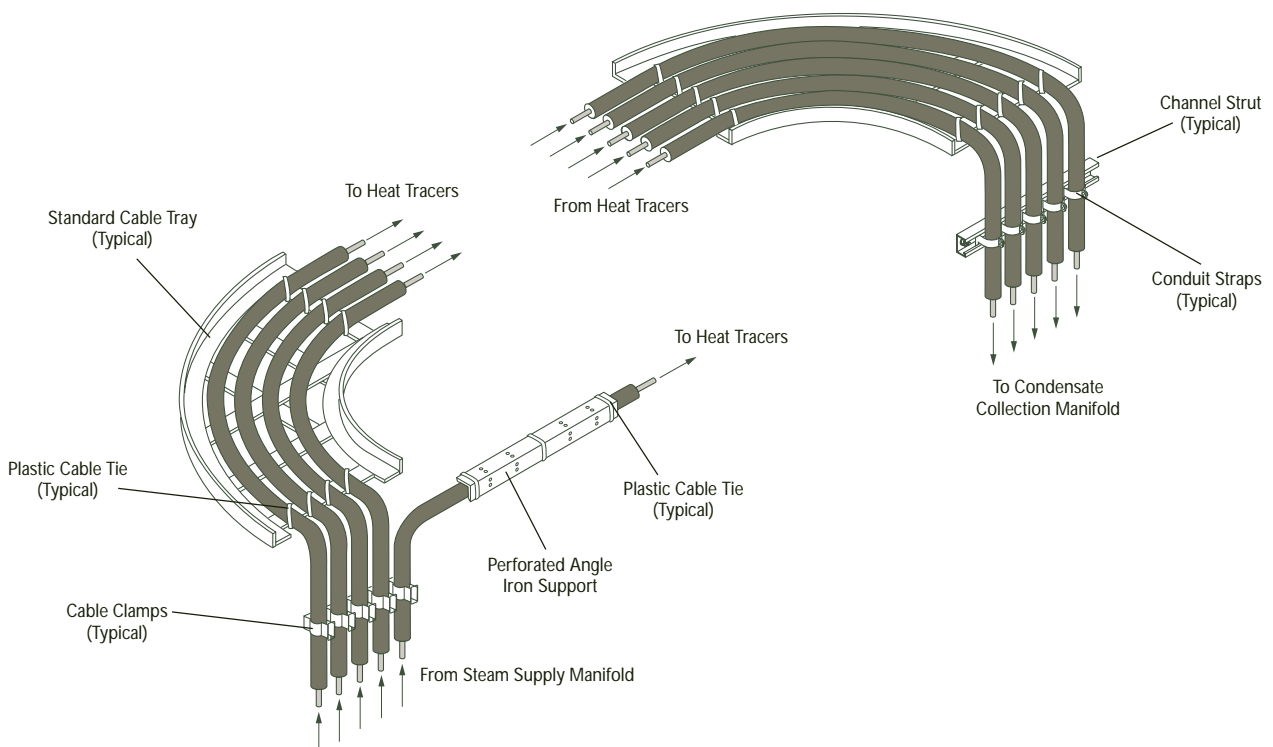

ThermoTube® Type SL

Illustration C: FAK-7 End Seal Kit Fabrication¹

1. Remove a 6 cm length of the black jacket. Next remove the heat reflective wrap and insulation as shown in the illustration.

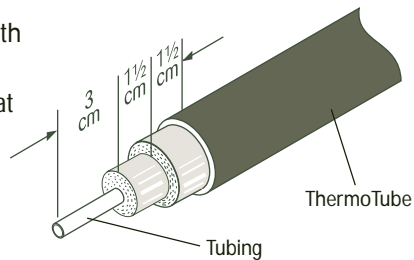

2. Deburr end of tubing making necessary field terminations.

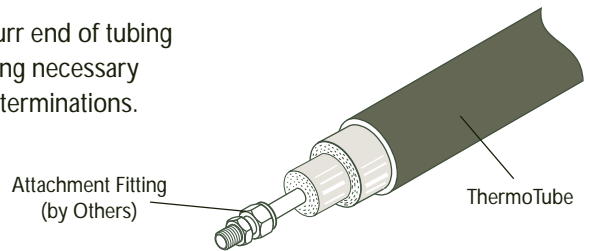

3. Liberally apply RTV sealant to end of ThermoTube insulation.

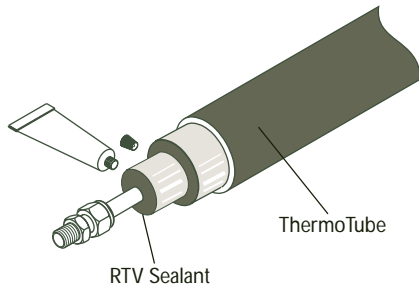

4. Wrap end of ThermoTube with silicone tape. Overlap the tape 50%, beginning 6 cm over ThermoTube insulation extending to the attachment fitting.

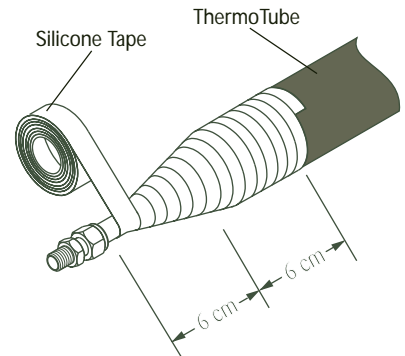
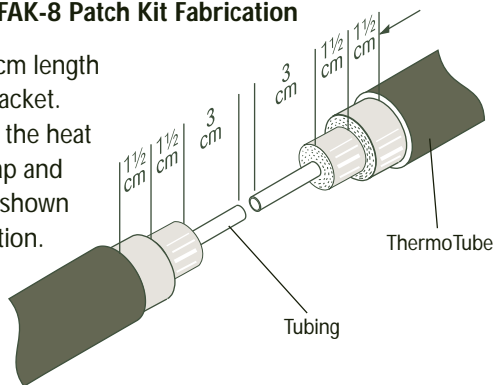
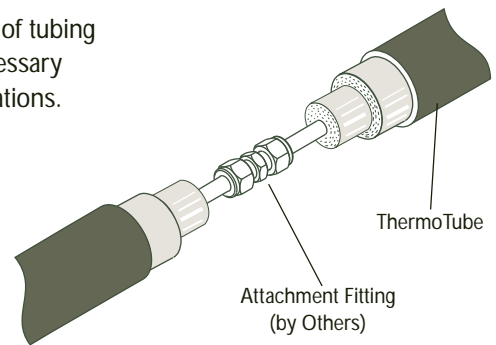

Illustration D: FAK-8 Patch Kit Fabrication

1. Remove a 6 cm length of the black jacket. Next remove the heat reflective wrap and insulation as shown in the illustration.



2. Deburr end of tubing making necessary field terminations.



3. Wrap glass fibre tape until level with ThermoTube insulation. Wrap heat reflective tape over fibre tape (25% overlap).

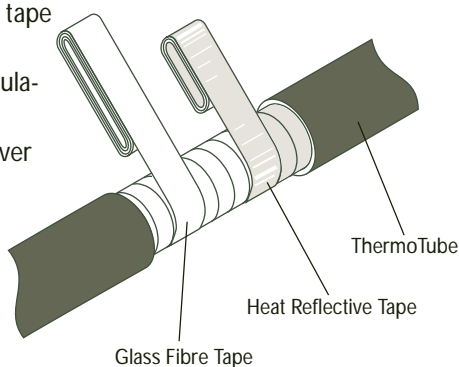

4. Wrap rubber tape around splice forming watertight seal. Allow self-sealing rubber tape to overlap ThermoTube a minimum of 2.5 cm on each side of splice.

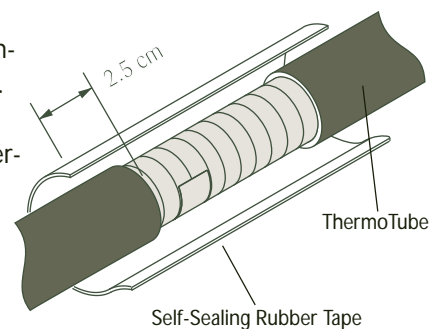

Note . . .

1. The FAK-7 kit contains sufficient materials for approximately 6 terminations. UV resistant ABS hard shell covers are available upon request; contact Thermon.



THERMON . . . The Heat Tracing Specialists®
www.thermon.com

ISO 9001
REGISTERED

tce Thermal Controls
and Electronics

TC-E B.V.
Nieuwland Parc 314c
2952 DD Alblasterdam
The Netherlands

+31 (0) 183 20 10 88
sales@tc-e.nl
www.tc-e.nl - www.heattrace.eu
Authorized Thermon distributor