

Heat Transfer Compounds

INSTALLATION PROCEDURES

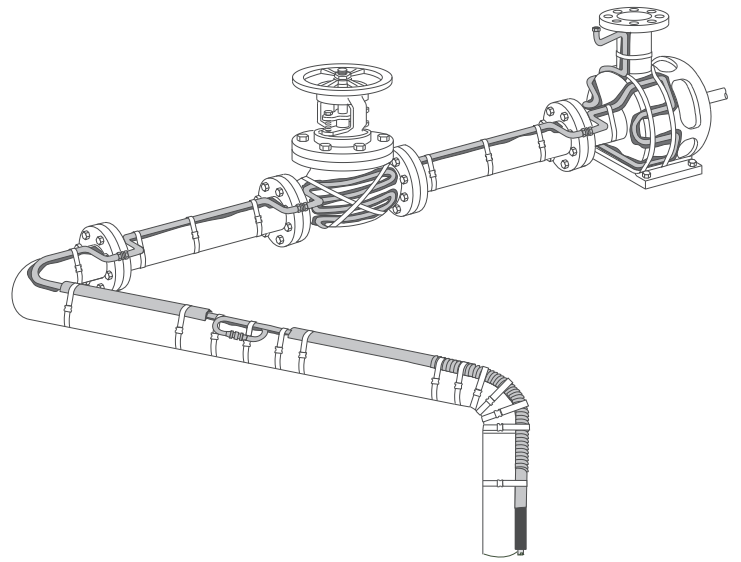

Heat Transfer Compounds

Compound Preparation

1. Prior to installing compound, review the minimum application temperature limits listed below.

Minimum Installation Temperatures		
Product	Ambient	Compound
T-3	0°C (32°F)	0°C (32°F)
T-85	0°C (32°F)	10°C (50°F)
T-99	0°C (32°F)	0°C (32°F)
SnapTrace®	-10°C (14°F)	-10°C (14°F)
Nonhardening	0°C (32°F)	≥ 25°C (77°F)

2. Moderate freezing temperatures will not damage the compound. However, it is recommended that the compound be stored in a heated room for eight hours prior to use.

Storage and Shelf Life (Unopened)

Product	Max. Storage Temp.	Shelf Life
T-3	49°C (120°F)	18 months
T-85	30°C (86°F)	1 year
T-99	49°C (120°F)	18 months
SnapTrace®	49°C (120°F)	Indefinite
Nonhardening	49°C (120°F)	Indefinite

Surface Preparation

1. Surface areas where heat transfer compound is to be installed must be clean in order to provide a good thermal connection with the substrate. Contact surfaces should be free of oil, grease, dirt, rust, scale, mill varnish and other contaminants. Follow all safety precautions when using any surface cleaning material and method.
2. If T-3 is to be installed on aluminum surfaces, a high temperature primer should be applied to the surface prior to installation.

Curing Procedures

1. ChannelTrace or hand-troweled applications using T-3 or T-99 require curing within 60 days of installation. Use copper or stainless steel tubing tracers. Carbon steel tubing tracers are not recommended.
2. T-3 and T-99 installed with a TFK channel can be cured at temperatures > 100°C (212°F). However, initial curing for 12-24 hours at 90°C to 100°C (194°F to 212°F) is recommended.
3. For hand-troweled applications, T-3 and T-99 must be cured at temperatures of 100°C (212°F) or less. Curing for 12-24 hours at 90°C to 100°C (194°F to 212°F) is recommended.
4. T-85 cures in 4-12 hours at temperatures between 100°C and 121°C (212°F and 250°F).
5. SnapTrace must be heated to a temperature of at least 93°C (200°F) to promote surface wetting and curing.
6. NH may be put into operation immediately. No curing required.

Precautionary and Cleanup Measures

1. Wearing gloves, safety glasses, and all other PPE recommended on the SDS is encouraged.
2. T-3 and T-99 grades are slightly alkaline and should be kept away from eyes.
3. Waterless soap may be used to remove compounds from hands, arms, etc.
4. When using T-85, equipment and spillages should be cleaned using approved solvents, emulsions or cleaning compounds. MEK and toluene will clean up this material but make sure they are approved for the workplace before using and follow all safety precautions.

T-3 and T-99

Installation on Straight Run Piping

- Tracers are to be run parallel and in direct contact with the process pipe. Tracer location should follow project specific instructions when given. If more than two tracers are used, they should be equally spaced circumferentially around the pipe.
- Install tube tracers in accordance with Illustrations A and B below. Pressure test tracing for leaks with steam pressure equal to or greater than the normal operating pressure or with suitable hydrostatic tests. Repair any leaks and retest until the tracing system is free of leaks.
- Fill TFK channel with T-3 or T-99 compound and use trowel to groove compound for tube tracer. The trowel should be used to remove heat transfer compound from the channel leaving a "V" groove. The mass of compound removed corresponds to the space which will be occupied by the tracer tube. Refer to Thermon's Estimating Bill of Materials, Form TSP0034 for compound coverage details.
- Press TFK channel over tracer.
- Attach channel to process piping with stainless steel banding and crimp-type seals as shown.
 - Banding should be a minimum of 12.7 mm wide x 0.51 mm thick (0.50" by 0.020") for TFK-4 systems.*
 - Banding should be a minimum of 12.7 mm wide x 0.76 mm thick (0.50" by 0.030") for TFK-7 or TFK-9 systems.*
 - Banding tool should exert a force of 4,448 N (1,000 lbs) or greater.*
- Insulate and weatherproof piping.

* Banding, crimp seals and tools meeting the required specifications are available from Thermon.

Note

T-3 and T-99 grades are water-soluble and should never be exposed to moisture. In all places where heat transfer compound has been applied with a hand trowel and the compound is exposed, temporary weather protection is required. Polyethylene film placed over heat transfer compound provides excellent weather protection. Remove film prior to installing insulation.

Illustration A: Installation of Tube Tracers

- Prior to installing TFK jackets, tracers may be temporarily positioned on the pipe using fixing tape or 16 AWG stainless steel tie wire every 0.6 to 1.2 m (2 to 4 ft).
- Place ChannelTrace™ system or SnapTrace® with TFK channel over tracer and wire.

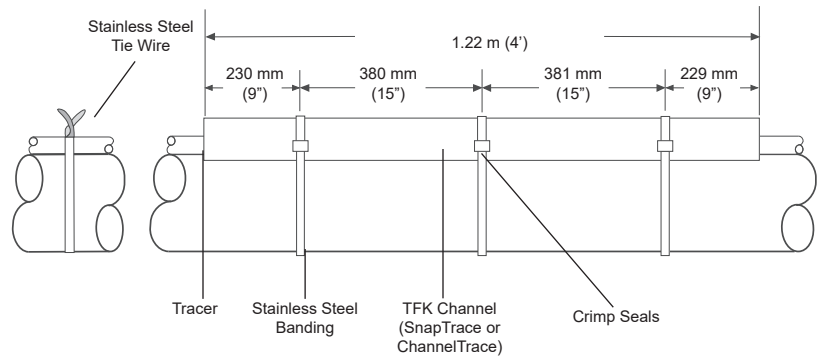
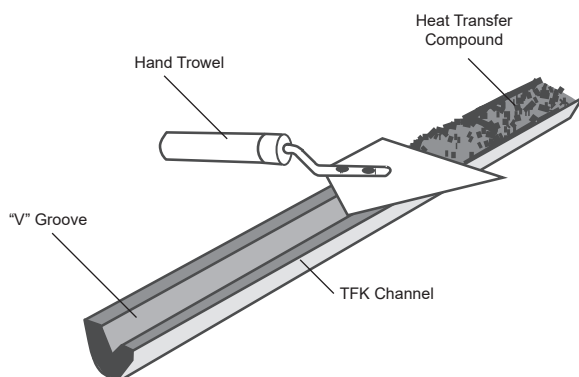
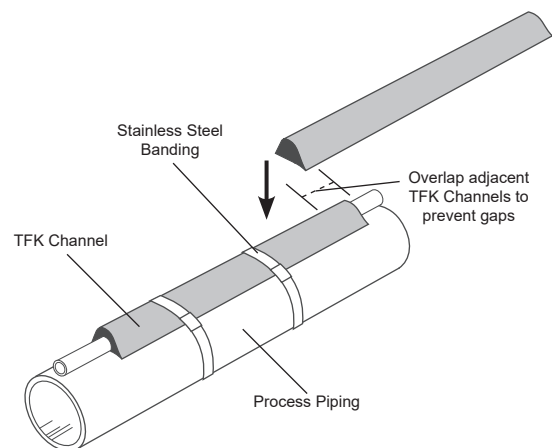

Illustration B: Installation of ChannelTrace System



Fill TFK channel with compound and use trowel to groove compound for tracer.



Press filled TFK channel over tracer and secure to process pipe using stainless steel banding.

Heat Transfer Compounds

Installation on Valves, Flanges, Elbows and Pumps

1. Install tube tracers in accordance with Illustration C below. Pressure test tracing for leaks with steam pressure equal to the normal operating pressure or with suitable hydrostatic tests. Repair any leaks and retest until the tracing system is free of leaks.
2. T-85 heat transfer compound is often used where moist and corrosive environments exist. This material may be applied as a fillet along each side of the tracer as shown in Illustration C. See Curing Procedures on page 2. Heat transfer compound is not generally applied over the top of a flange.

Where moist or corrosive conditions are not likely to be present T-3 or T-99 heat transfer compounds may be hand trowelled onto tracers. These materials should cover the top of the tracer by a minimum of 6 mm (1/4"), completely embedding the tracer. All voids between the tracer and the contact surface should be filled to ensure maximum heat transfer. See Curing Procedures on page 2. On valves and other irregular shaped equipment where the material is installed in a large mass, the curing period should be at least 24 hours.

3. Insulate and weatherproof equipment.

Illustration C: Heat Transfer Compound Installation

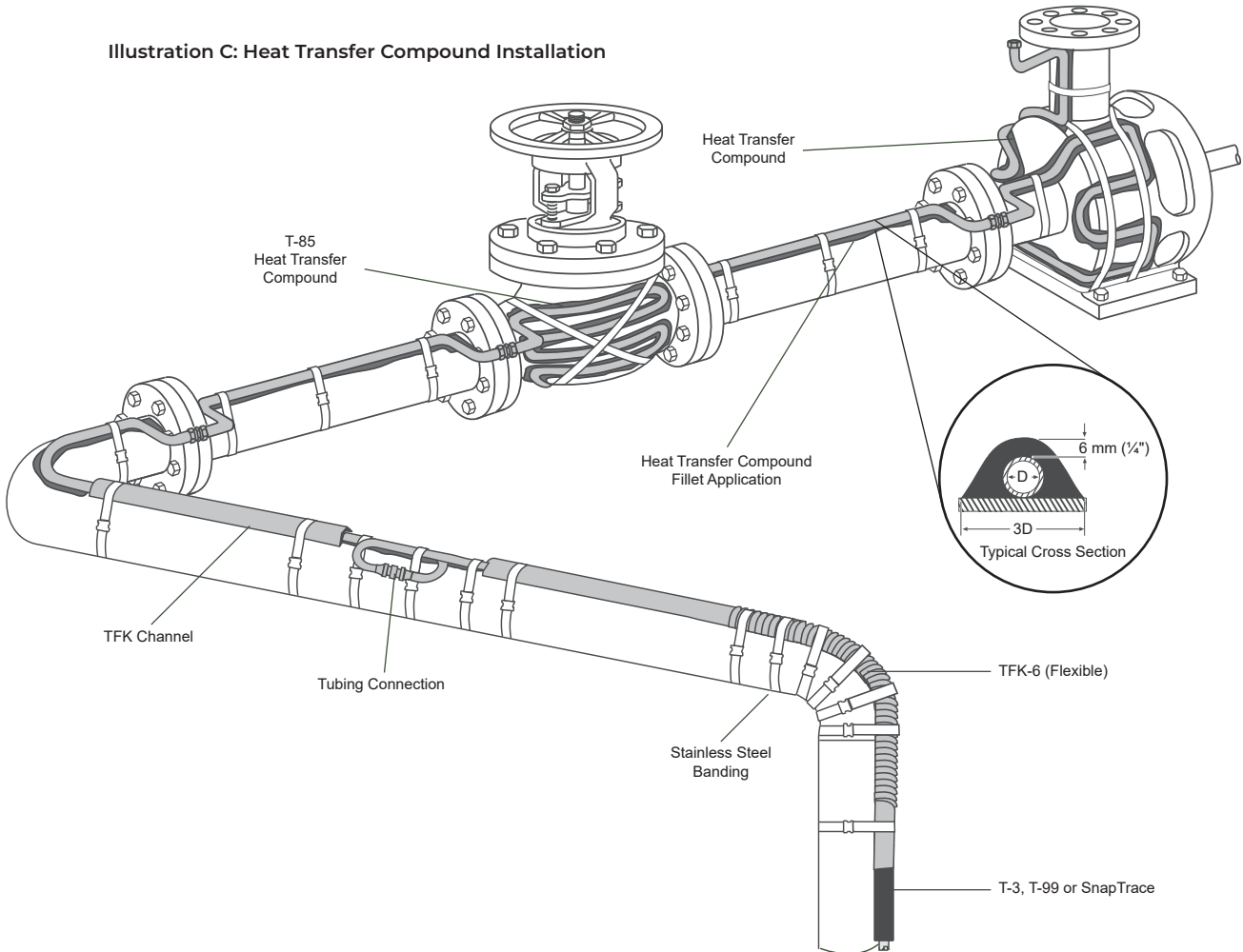

INSTALLATION PROCEDURES

T-85

Installation on Straight Run Piping

Tracers are to be run parallel and in direct contact with the process pipe. Tracer location on pipe is to be where most accessible. If more than two tracers are used, they should be equally spaced circumferentially around the pipe.

1. Install tracers as shown below. Pressure test tracing for leaks with steam pressure equal to the normal operating pressure or with suitable hydrostatic tests. Repair any leaks and retest until the tracing system is free of leaks.
2. Tracers may be temporarily positioned on the pipe using fixing tape or 14-gauge stainless steel tie wire every 0.6 to 1.2 m (2 to 4 ft). Prior to installing T-85 compound, secure the tracer to the pipe on 0.6 m (2 ft) centers using T2SSB stainless steel banding and crimp seals for 10 mm or 12 mm O.D. (3/8" or

1/2") tracers and T3SSB for 20 mm O.D. (3/4") tracers or larger. The bands should be as tight as possible without denting or flattening the tracer.

3. Apply fillet of compound along sides of the tracer as shown on Illustration D below. Refer to Thermon's Estimating Bill of Materials, Form TSP0034 for compound coverage details.
4. Insulate and weatherproof equipment.

Note

T-85 is not soluble in water. However, systems employing T-85 which are not insulated should be temporarily protected from the erosive or corrosive action of rain or moisture during the curing period.

Illustration D: Fillet Application

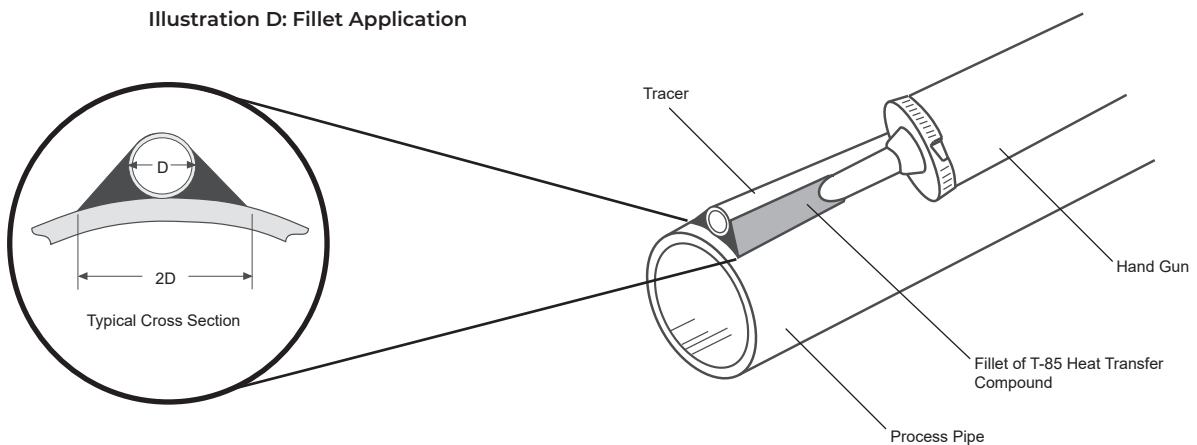
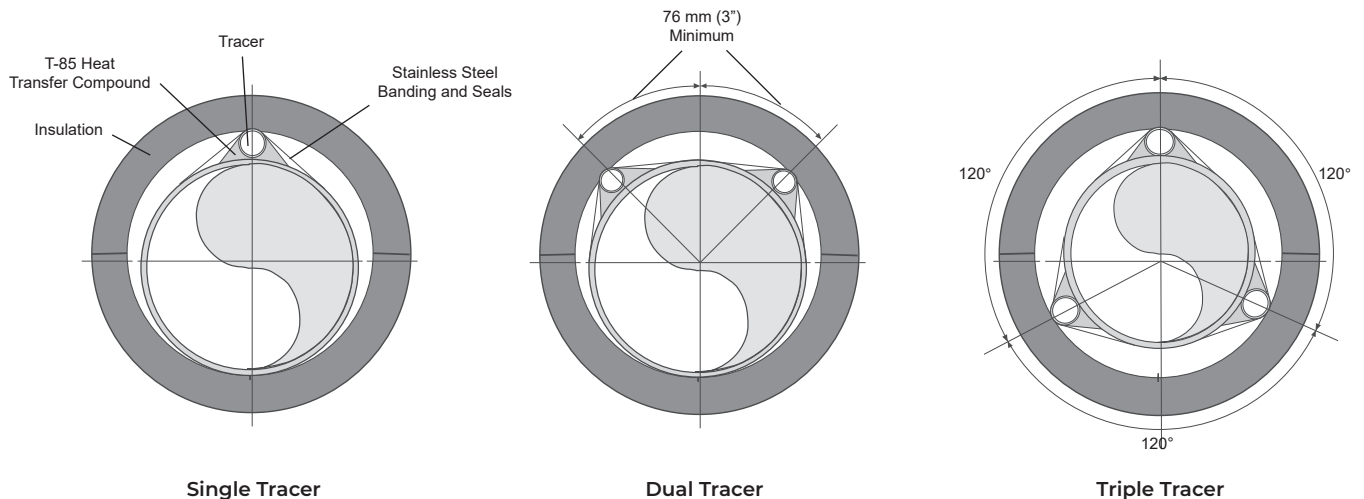

Illustration E: T-85



Heat Transfer Compounds

SnapTrace®

Installation on Straight Run Piping

Tracers are to be run parallel and in direct contact with the process pipe. Tracer location on pipe is to be where most accessible. If more than two tracers are used, they should be equally spaced circumferentially around the pipe as shown in Illustration G. For complete SnapTrace specifications refer to Thermon Form TSP0018.

1. Install tube or pipe tracers in accordance with Illustration A (see T-3 and T-99 installation). Pressure test tracing for leaks with steam pressure equal to or greater than the normal operating pressure or with suitable hydrostatic tests. Repair any leaks and retest until tracing system is free of leaks.
2. Place SnapTrace over tracer as shown in Illustration F below.
3. Position TFK channel over SnapTrace.

4. Attach jacket to process piping with stainless steel banding and crimp-type seals as shown.
 - Banding should be a minimum of 12.7 mm wide x 0.51 mm thick (0.50" x 0.020") for ST-1 and ST-2 systems.*
 - Banding tool should exert a force of 4,448 N (1,000 lbs) or greater.*

* Banding, crimp seals and tools meeting the required specifications are available from Thermon.

5. Insulate and weatherproof piping.

Note: In all places where SnapTrace is exposed, temporary weather protection is required. Polyethylene film placed over SnapTrace provides excellent weather protection. Remove film prior to installing insulation.

Illustration F: Installation of SnapTrace Compound

Place SnapTrace and channel over tracer.

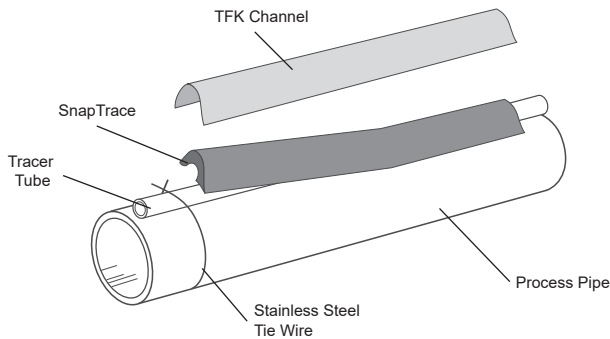

Band SnapTrace to pipe (see Illustration A).

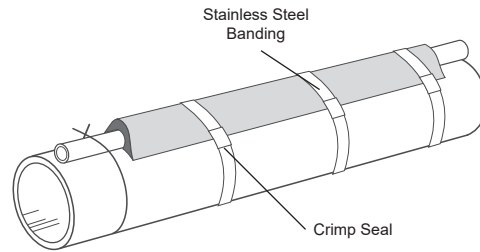
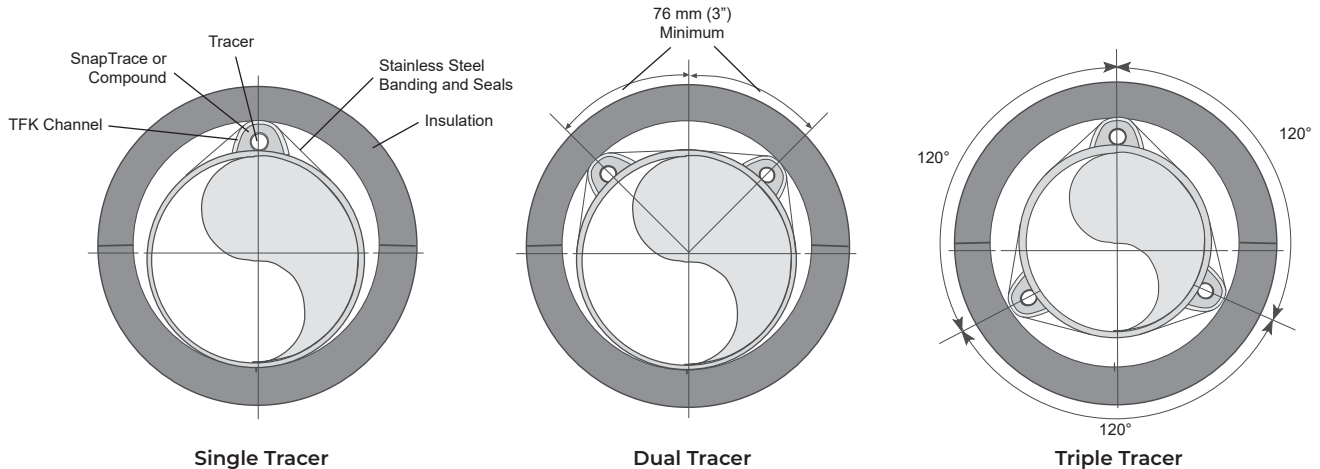

Illustration G: SnapTrace and ChannelTrace™



INSTALLATION PROCEDURES

NH Nonhardening

Installation

1. Approximate thickness of compound required is 3.2 mm (1/8") to 6.35 mm (1/4") covering the entire contact side surface area of coil(s). Refer to Thermon's Estimating Bill of Materials, Form TSP0034 for compound coverage details.
2. Trowel on and spread the hot heat transfer compound over the coil surface(s) using a mortar trowel. After spreading the compound over the entire surface, ensure that sufficient compound is installed to fill the normal air voids and other irregular surfaces which may exist on the vessel or coil.
3. No curing is required.
4. Install the coil(s) on the vessel wall.

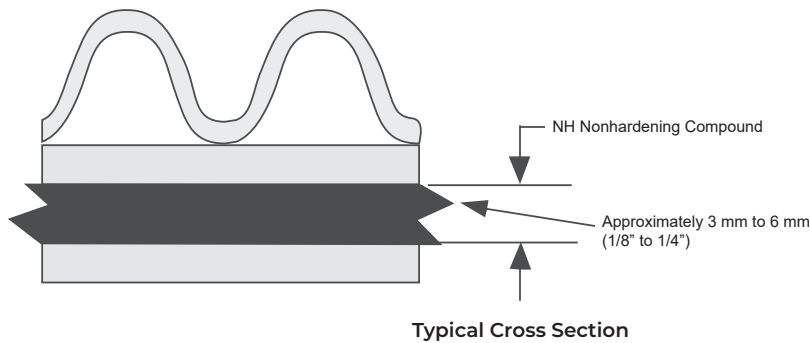
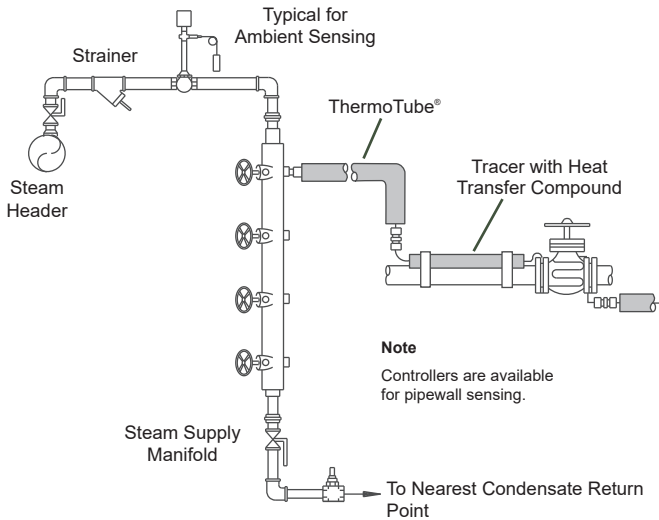
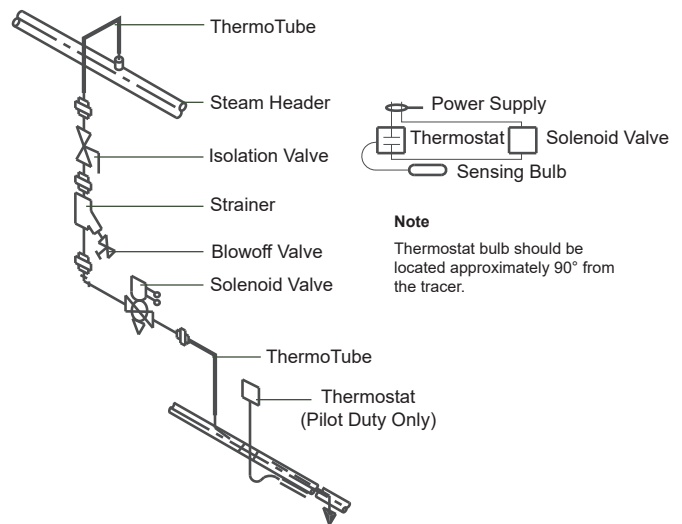

Illustration H: Temperature Control Details



Steam Temperature Control Using "Self-Actuated" Mechanical Controller with Prefabricated Manifold



Steam Temperature Control Using Thermostat and Solenoid Valve for Pipe or Ambient Sensing (Field Assembly)

Illustration I: Trapping and Condensate Handling (Typical Details)

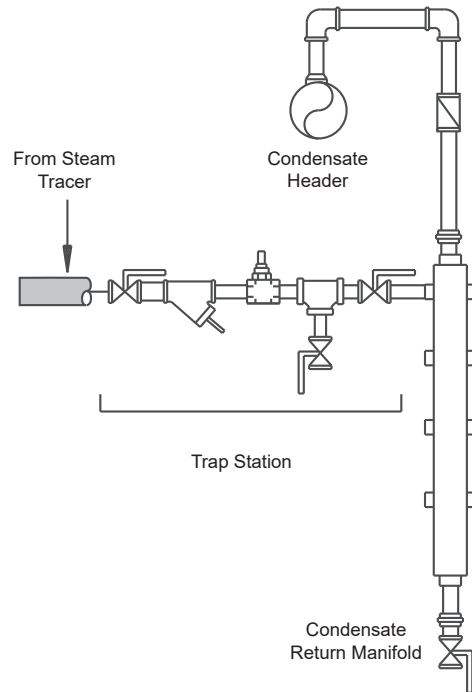
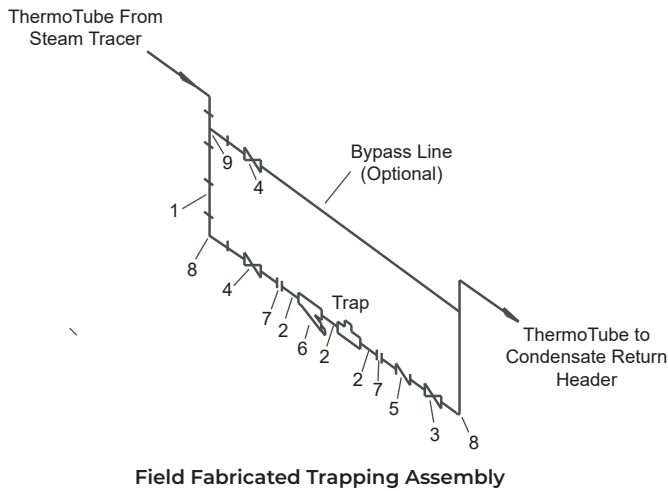

Prefabricated Trap Station and Condensate Manifold

Item No.	Description	Nominal Size
1	Pipe Schedule 80 CS	1/2"
2	Nipple Schedule 80	1/2" x 3"
3	Gate Valve 600 LB CS	1/2"
4	Globe Valve 600 CS	1/2"
5	Check Valve 600 LB CS	1/2"
6	Y-Strainer 600 LB CS	1/2"
7	Union 3000 LB CS	1/2"
8	Elbow 3000 LB CS	1/2"
9	Tee Schedule 80 CS	1/2"

