

# Terminator™ ZL-WP

Lighted Power Connection/  
End Termination Kit

## INSTALLATION PROCEDURES

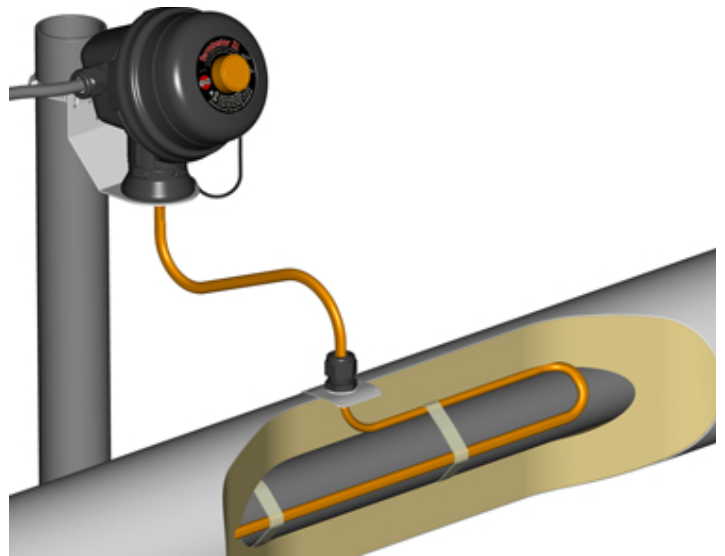

For Power Connection, In-Line Splice Connection,  
T-Splice Connection, or End Termination Applications



# Terminator™ ZL-WP

The following installation procedures are suggested guidelines for the installation of the Terminator ZL-WP Kit. For translations other than English and local language translation provided here, please contact Thermon. The English language installation procedure shall govern.

## Receiving, Storing and Handling

1. Inspect materials for damage incurred during shipping.
2. Report damages to the carrier for settlement.
3. Identify parts against the packing list to ensure the proper type and quantity has been received.
4. Store in dry location.

## Kit Contents



Item	Quantity	Description
1	1	Expediter Assembly Support Cap with O-Ring Threaded Grommet Compressor Grommet Support Base with O-Ring
2	1	Junction Box Lid
3	1	Junction Box Base with O-Ring
4	1	Nut
5	1	Banding
6	1	Terminal Blocks with DIN Rail (Refer to terminal specifications for maximum allowable wire size)
7	1	Junction Box Cord
8	1	Blind Plug
9	1	Bracket
10	3	Screws
11	3	Washers

## Order Separately

### PETK Power and End Termination Kits (per cable)

PETK-1 for RSX, VSX-HT, BSX

PETK-2 for KSX, HTSX, USX

PETK-3 for HPT, FP

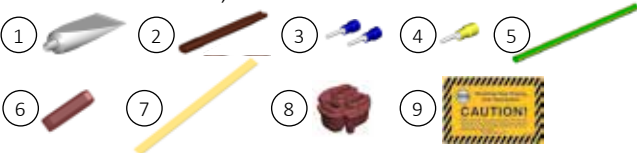

Item	Quantity	Description
1	1	RTV Tube
2	1	Power Connection Boot
3	2	Conductor Wire Pins
4	1	Braid Wire Pin
5	1	Ground Sleeve
6	1	End Cap
7	1	Tape Strip (PETK-3 only)
8	1	GRW-G Grommet (PETK-3 only)
9	1	End Termination Caution Label

# INSTALLATION PROCEDURES

## Order Separately

### IEK Insulation Entry Kit (per cable)

IEK-SXL: for RSX, VSX-HT

IEK-SXM for BSX

IEK-SXS for KSX, HTSX, USX

IEK-HPT for HPT



## Dimensions

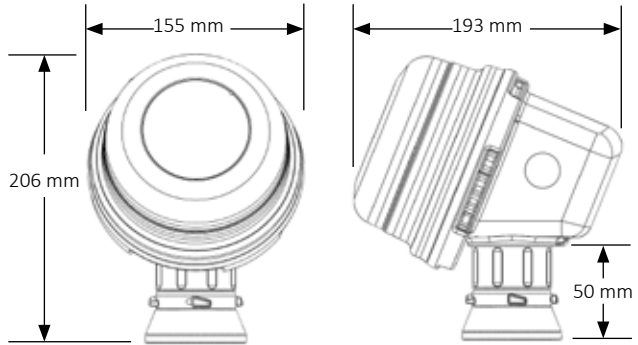

## Specific Conditions of Use

1. Temperature code is based on the rating of the electrical heat tracing cables for which the connection kits are intended to be used at  $-60^{\circ}\text{C} < T_a < +55^{\circ}\text{C}$  for T6...T4

## Warnings

- Due to the risk of electrical shock, arcing and fire caused by product damage or improper usage, installation or maintenance, a ground-fault protection device is required.
- Installation must comply with Thermon requirements (including form PN 50207U for Ex systems) and be installed in accordance with the regulations as per the norm EN IEC 60079-14 for hazardous areas (where applicable), or any other applicable national and local codes.
- Component approvals and performance ratings are based on the use of Thermon specified parts only.
- De-energize all power sources before opening enclosure.
- Avoid electrostatic charge. Clean only with a damp cloth.
- Keep ends of heating cable and kit components dry before and during installation.
- Minimum bending radius of heating cable is 32 mm (except HPT is 57 mm and FP is 19 mm).
- Individuals installing these products are responsible for complying with all applicable safety and health guidelines. Proper Personal Protective Equipment (PPE) should be utilized during installation. Contact Thermon if you have any additional questions.
- Consult the manufacturer for dimensional information on the flameproof joints for repair.

## Tools Required

3 mm  
8 mm



## Certifications/Approvals

IP66- $60^{\circ}\text{C} \leq T_a \leq +55^{\circ}\text{C}$

Ordinary & Hazardous Locations



FMG 10.0022X Ex db eb IIC T6...T4  
Ex tb IIIC T85°C...T135°C



0344 2809 Ex II 2 GD Ex db eb IIC T6...T4, Ex tb IIIC T85°C...T135°C, FM 10ATEX0058X

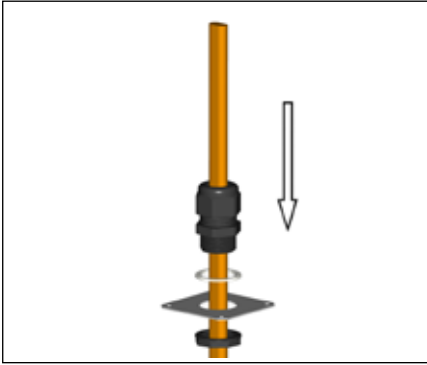

**1.** Slide appropriate IEK insulation entry kit components onto cable.

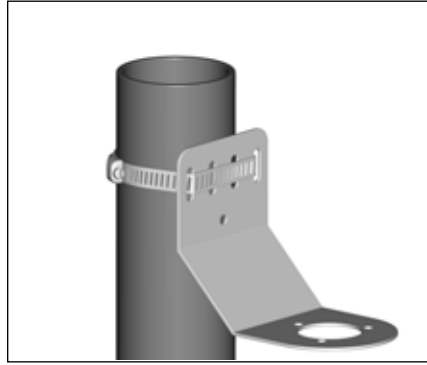

**2a.** Mounting Method 1: Secure wall mount bracket to mounting surface using pipe band provided with kits.



**2b.** Mounting Method 2: Secure wall mount bracket to mounting surface using customer supplied screws, flat washers, and nuts.

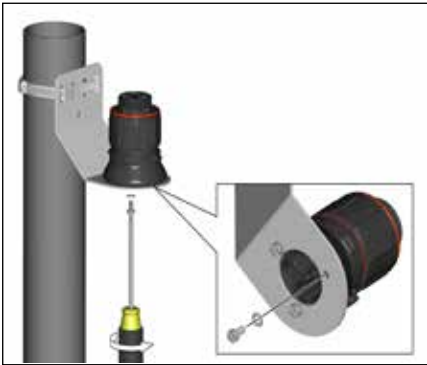

**3.** Mount expediter to bracket using M5 x 8 mm screws and M5 lock washers.

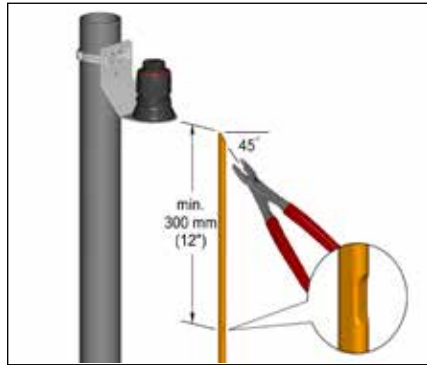

**4.** Locate bus connection (HPT and FP only) as shown. Cut end of cable at angle to aid in piercing grommet. Leave additional cable for expansion as needed.

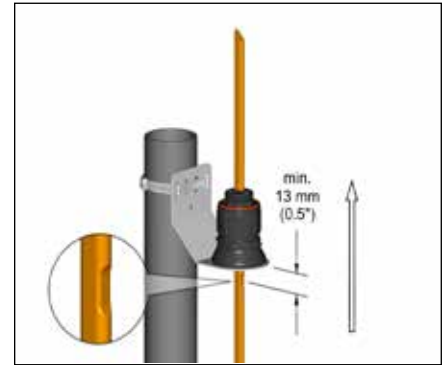

**5.** Insert cable into expediter. Make sure bus connection (HPT and FP only) remains outside of expediter.

Note: For HPT and FP cable, exchange grommet in Terminator with GRW-G provided in PETK-3.

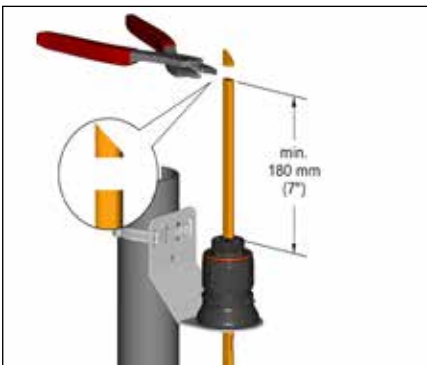

**6.** Cut off end of cable.



**7.** Terminate cable with appropriate PETK termination kit. Refer to PETK installation instructions.

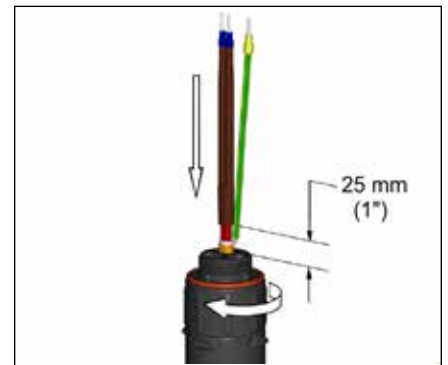

**8.** Push excess cable back through expediter. Tighten cap securely. Tape cable expansion loop to pipe.

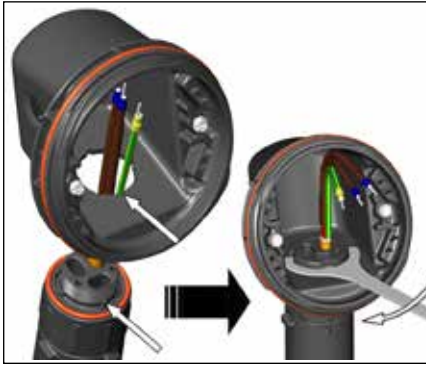

**9.** Mount junction box base on expediter. Make sure to align slots to properly orient junction box base. Tighten nut with Terminator-LN-Tool. If mounting horizontally, threaded gland holes must face downward.

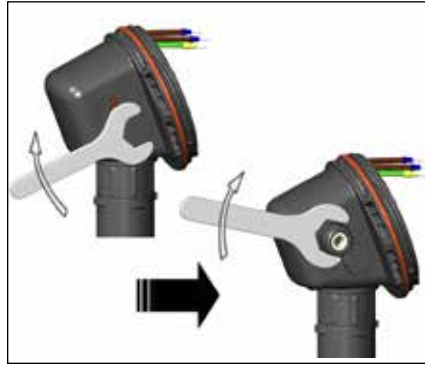

**10.** Install M25 power gland (order separately) and M25 blind plug. For in-line splice, T-splice, or end termination, install additional M25 blind plug (order M25-B-EXE separately) instead of M25 power gland.



**11.** Install power cable.

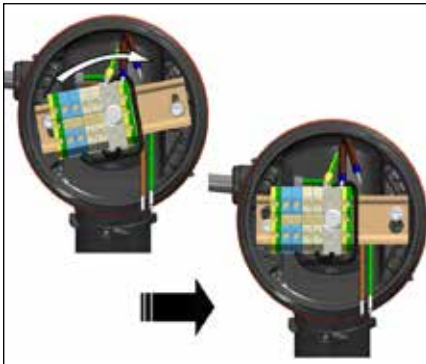

**12.** Install quick mount terminal blocks and tighten screws (if necessary). Complete system wiring. Terminal set screws shall be tightened to a torque value of 1.4 Nm (12.4 lb-in). See page 4 for wiring details.

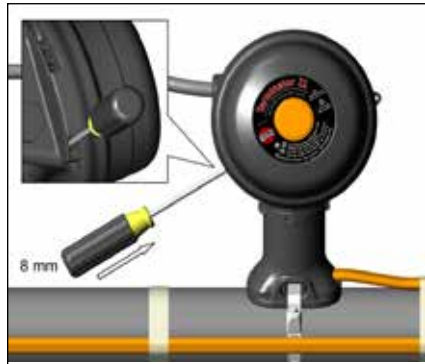

**13.** Install junction box lid and twist hand tight. Insert screwdriver into ratchet slots located on side of junction box base.



**14.** Use screwdriver to ratchet on junction box lid. Lid will rotate 30 degrees. To remove lid, repeat steps 14 and 15 but in the opposite direction.

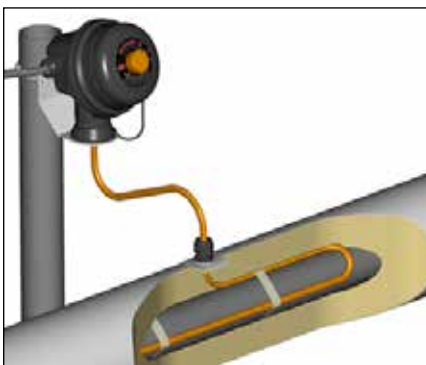

**15.** Install IEK insulation entry kit to seal heating cable penetration through insulation cladding.

### Wiring Details

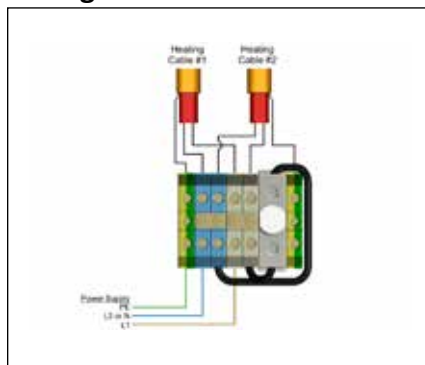

Power Connection (1 to 2 Heating Cables)

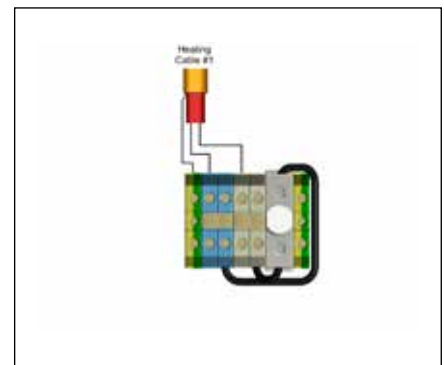

End Termination (1 Heating Cable Only)

