

# Terminator™ ZP-MI-WP Power Connection Kit INSTALLATION PROCEDURES



For Power Connection, In-Line Splice Connection, or T-Splice Connection With MI - Mineral Insulated Heating Cable Sets



# Terminator™ ZP-MI-WP

The following installation procedures are suggested guidelines for the installation of the Terminator ZP-MI-WP Kit. For translations other than English and local language translation provided here, please contact Thermon. The English language installation procedure shall govern.

## Kit Contents

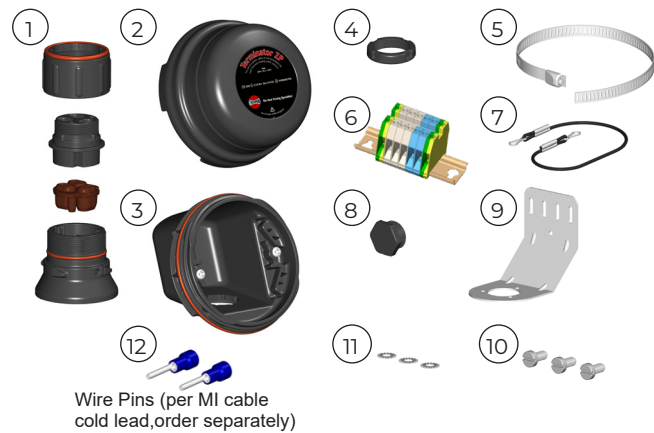

Item	Quantity	Description
1	1	Expediter Assembly Support Cap with O-Ring Threaded Grommet Compressor Grommet Support Base with O-Ring
2	1	Junction Box Lid
3	1	Junction Box Base with O-Ring
4	1	Nut
5	1	Banding
6	1	Terminal Blocks with DIN Rail (Refer to terminal specifications for maximum allowable wire size.) Jumpers loose supplied.
7	1	Junction Box Cord
8	2	Blind Plug
9	1	Bracket
10	3	Screws
11	3	Washers
12	2	Wire Pins

## Certifications/Approvals

IP66 -60°C ≤ Ta ≤ +55°C  
Ordinary & Hazardous Locations

FMG 10.0022X Ex eb IIC T6...T4 Gb  
Ex tb IIIC T85°C...T135°C Db

0344 II 2 GD Ex eb IIC T6...T4 Gb, Ex tb IIIC T85°C...T135°C Db  
FM 10ATEX0058X

### Specific Conditions of Use

Avoid electrostatic charge. Clean only with damp cloth.

# INSTALLATION PROCEDURES

## Dimensions

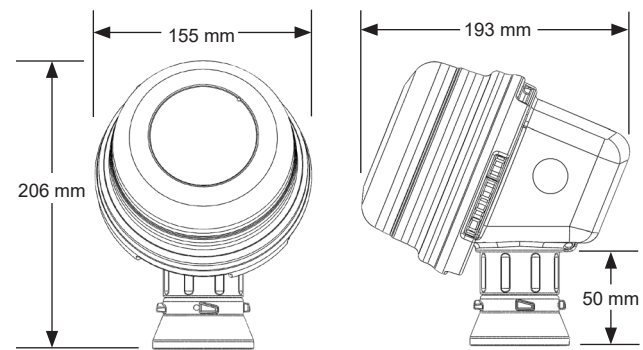

## Warnings

- Due to the risk of electrical shock, arcing and fire caused by product damage or improper usage, installation or maintenance, a ground-fault protection device is required.
- Installation must comply with Thermon requirements (including form PN 50207U for Ex systems) and be installed in accordance with the regulations as per the norm EN IEC 60079-14 for hazardous areas (where applicable), or any other applicable national and local codes.
- Component approvals and performance ratings are based on the use of Thermon specified parts only.
- De-energize all power sources before opening enclosure.
- Avoid electrostatic charge. Clean only with a damp cloth.
- Keep ends of heating cable and kit components dry before and during installation.
- Minimum bending radius of heating cable is 6 times the cable outer diameter.
- Individuals installing these products are responsible for complying with all applicable safety and health guidelines. Proper Personal Protective Equipment (PPE) should be utilized during installation. Contact Thermon if you have any additional questions.

## Tools Required

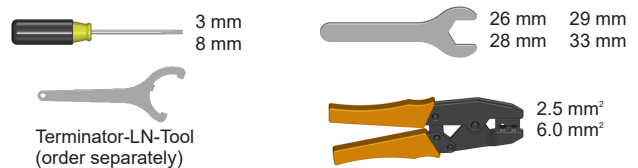

## Installation Details

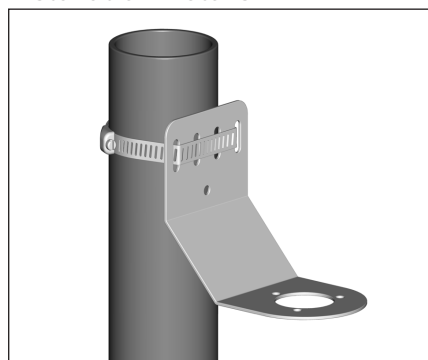

**1a.** Mounting Method 1: Secure wall mount bracket to mounting surface using pipe band.

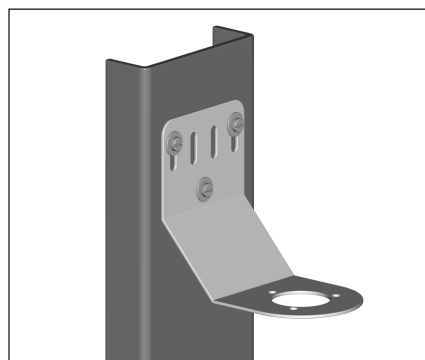

**1b.** Mounting Method 2: Secure wall mount bracket to mounting surface using screws, washers, and nuts (customer provided)

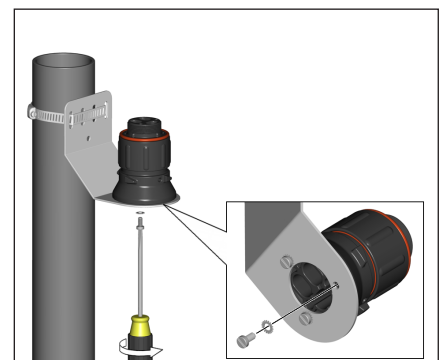

**2.** Mount Expediter to bracket using M5 screws and lock washers.

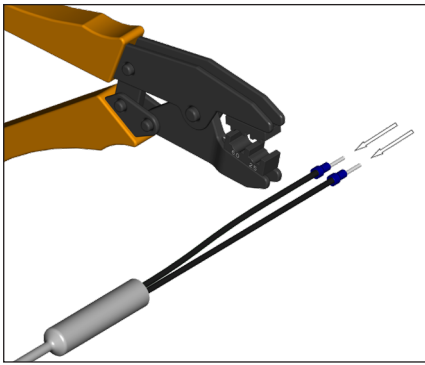

3. Crimp appropriate wire pins (2.5 mm<sup>2</sup> or 6 mm<sup>2</sup>) on MI cable cold lead wires if required as per client/project specification (order separately).

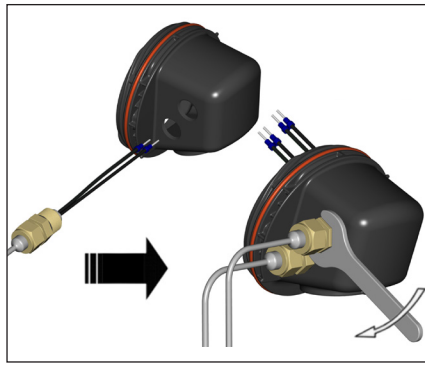

4. Route MI cable cold leads through M20 threaded entries. Screw cable glands into junction box.

**CAUTION** Do not over-tighten to ensure O-ring is not damaged during installation.

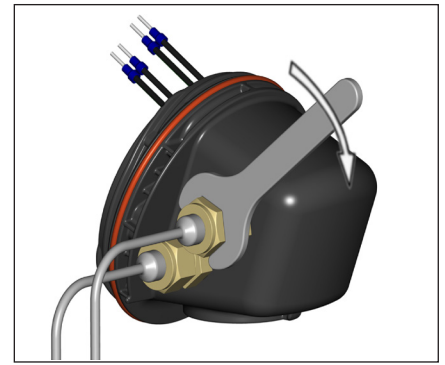

5. Center cold lead sleeve inside cable gland. Tighten cable glands until ferrule begins to make contact with cold lead sleeve and cold lead sleeve cannot be moved by hand. Tighten cable gland 1/8 additional turn or to a torque value of 16 Nm (142 lb-in).

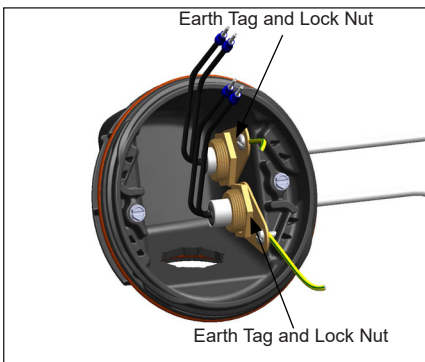

6. Install user supplied M20 Earth Tag and Lock Nut to threaded M20 Gland.

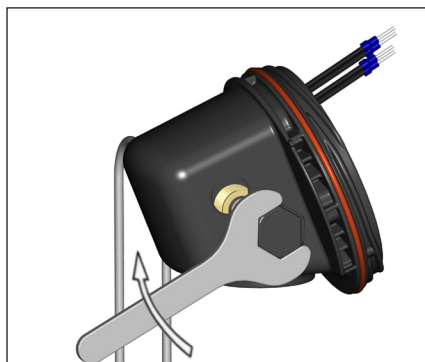

7. Install M20 blind plug in remaining M20 threaded entry (if necessary). Additional M20 blind plug (order M20-B-EXE) will be required if only installing one gland.

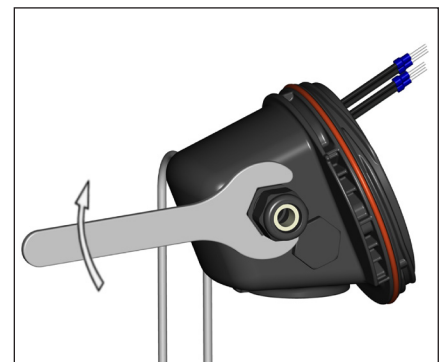

8. Install M25 power gland (customer supplied) in M25 threaded entry. For in-line splice or 3 phase wye connection, install M25 blind plug (order M25-B-EXE separately) instead of M25 power gland.

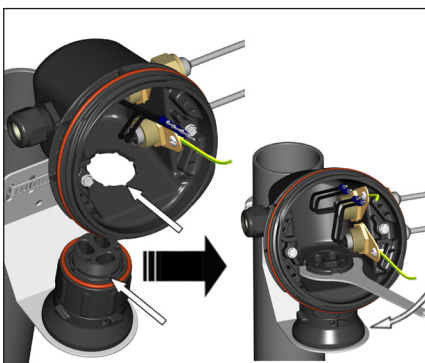

9. Mount junction box base on expediter. Make sure to align slots to properly orient junction box base. Tighten nut with Terminator-LN-Tool. If mounting horizontally, threaded gland holes must face downward.

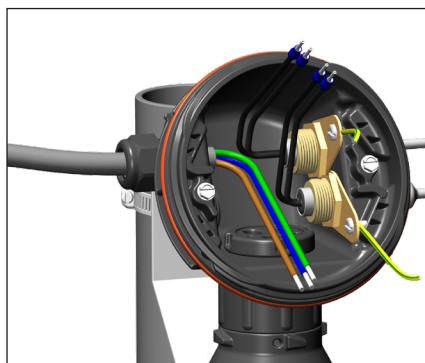

10. Install power cable (if necessary).

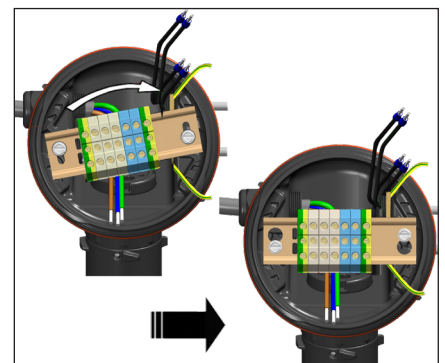

11. Install quick mount terminal blocks and tighten screws (if necessary).

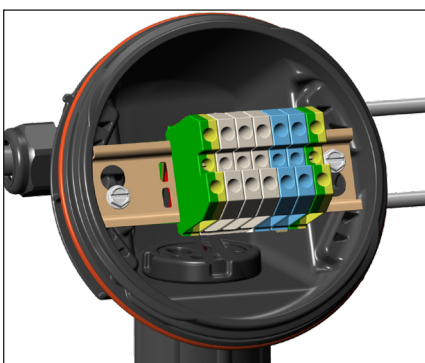

12. Complete system wiring. Terminal set screws shall be tightened to a torque value of 1.4 Nm (12.4 lb-in). See last page for wiring details.

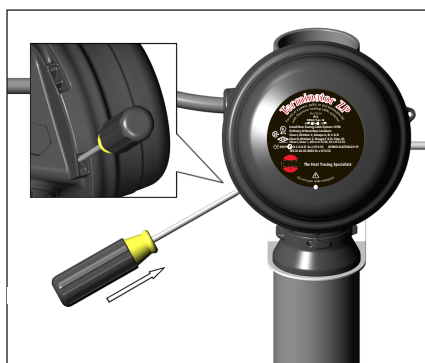

13. Install junction box lid and twist hand tight. Insert screwdriver into ratchet slots located on side of junction box base.

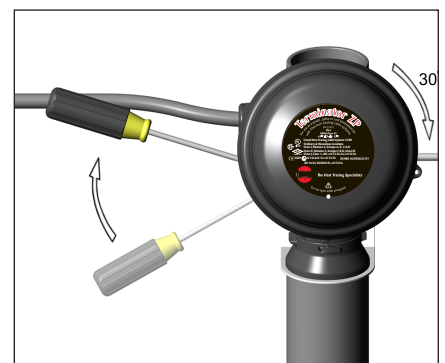

14. Use screwdriver to ratchet on junction box lid. Lid will rotate 30 degrees.

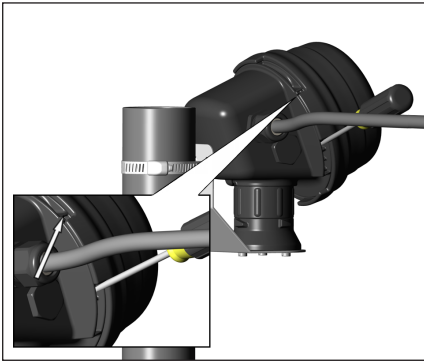

15. Lid latch mechanism fully engaged. To remove lid, repeat steps 12 and 13 but in the opposite direction.

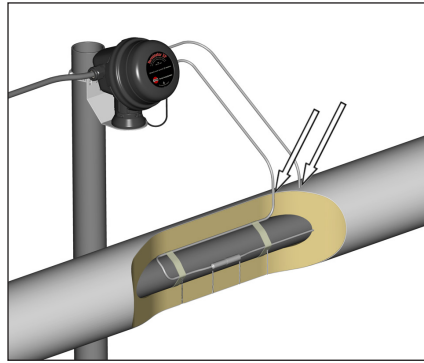

16. Seal penetration through insulation cladding.

Wiring Details (Two Conductors)

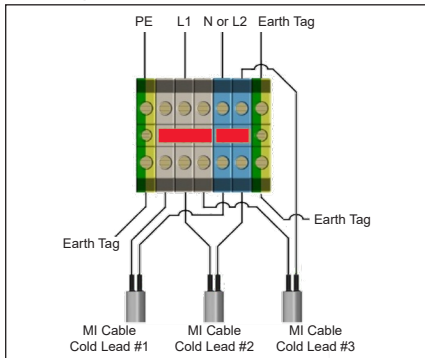

A1. Single phase or phase-phase power connection. Install jumpers as shown.

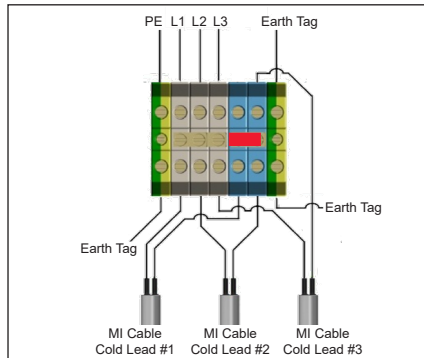

A2. 3-phase power and Wye connection. Install jumper to create Wye connection as shown.

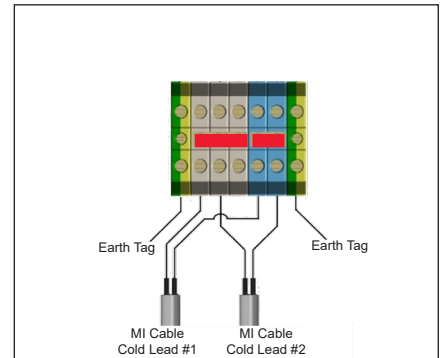

A3. In-line splice. Install jumpers as shown.

Wiring Details (Single Conductor)

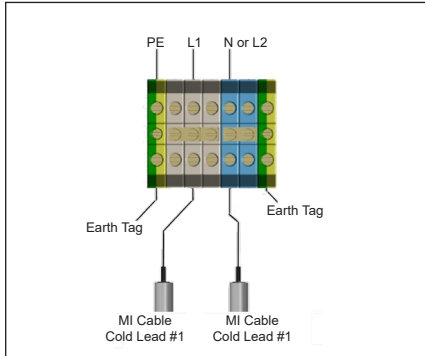

A1. Single phase or phase-phase power connection. Do not install jumpers.

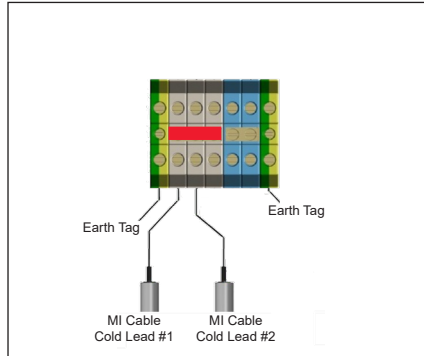

A2. In-line splice. Install jumpers as shown.

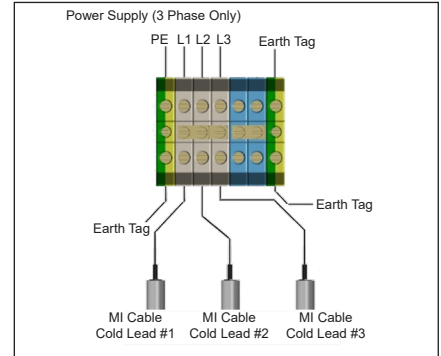

A3-1. 3-phase power connection. Do not install jumpers.

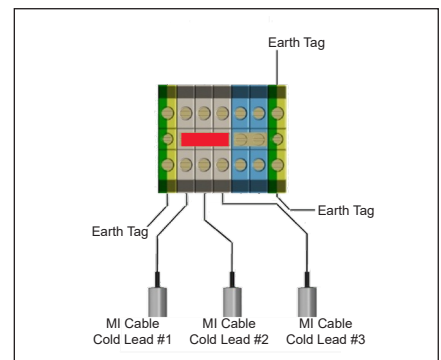

A3-2. 3-phase Wye connection. Install jumpers as shown.

