

# Terminator™ ZP-R-XP Connection Kit

## INSTALLATION PROCEDURES



For Use With TESH and TES(X)L  
Series Constant Watt Heating Cables



**The Heat Tracing Specialists®**

# Terminator™ ZP-R-XP

## INSTALLATION PROCEDURES

The following installation procedures are suggested guidelines for the installation of the Terminator ZP-R-XP Kit. For translations other than English and local language translation provided here, please contact Thermon. The English language installation procedure shall govern.

### Receiving, Storing and Handling . . .

1. Inspect materials for damage incurred during shipping.
2. Report damages to the carrier for settlement.
3. Identify parts against the packing list to ensure the proper type and quantity has been received.
4. Store in dry location.

### Kit Contents . . .



Item	Quantity	Description
1	1	Expediter Assembly Support Cap with O-Ring Threaded Grommet Compressor Grommet Support Base with O-Ring
2	1	Junction Box Lid
3	1	Junction Box Base with O-Ring & M25 Dust Cap
4	1	Nut
5	1	Banding
6	1	Terminal Block & Bridge (separately)
7	1	Junction Box Cord
8	1	Blind Plug
9	1	Banding Guide

### Order Separately . . .

#### PETK Power and End Termination Kits (per cable)

- PETK-5 for direct connection  
 PETK-10 & 11 for cold lead connection

### Dimensions . . .

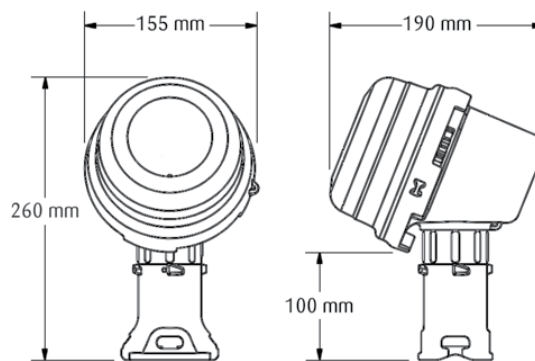

### Warnings . . .

- Due to the risk of electrical shock, arcing and fire caused by product damage or improper usage, installation or maintenance, a ground-fault protection device is required.
- Installation must comply with Thermon requirements (including form PN 50207U for Ex systems) and be installed in accordance with the regulations as per the norm EN IEC 60079-14 for hazardous areas (where applicable), or any other applicable national and local codes.
- Component approvals and performance ratings are based on the use of Thermon specified parts only.
- De-energize all power sources before opening enclosure.
- Avoid electrostatic charge. Clean only with a damp cloth.
- Keep ends of heating cable and kit components dry before and during installation.
- Minimum bending radius of heating cable is five (5) times the cable outer diameter.
- Individuals installing these products are responsible for complying with all applicable safety and health guidelines. Proper Personal Protective Equipment (PPE) should be utilized during installation. Contact Thermon if you have any additional questions.

### Tools Required . . .

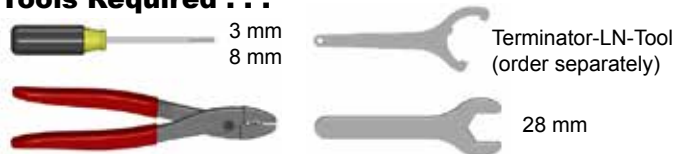

### Certifications/Approvals . . .

IP66  
 -60°C ≤ Ta ≤ +55°C  
 Ordinary & Hazardous Locations  
 CE 1725 Ex II 2 GD Ex eb IIC T4-T6, Ex tb IIIC T135°C-T85°C FM10ATEX0058X

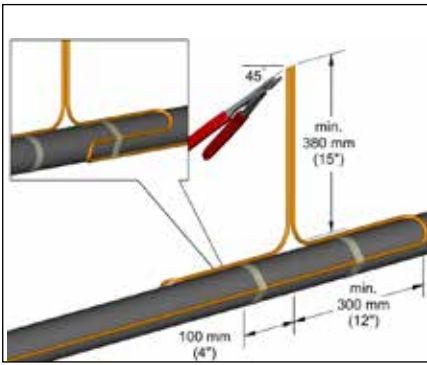

**1.** Cut end of cable at angle to aid in piercing grommet. Leave additional cable for expansion loop. See page 4 for multiple cable installation tips.

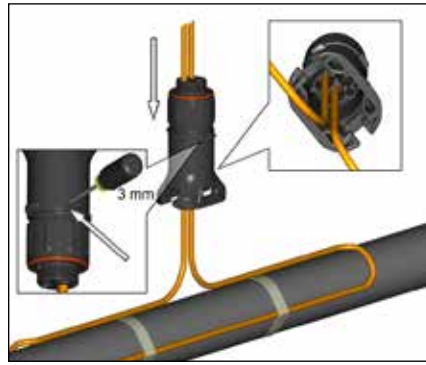

**2.** Insert cable into expediter. If mounted on bottom or side of pipe, punch out weep hole.

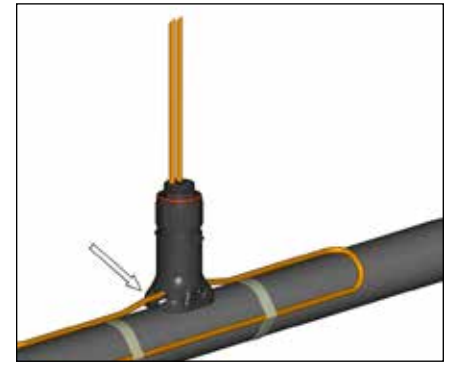

**3.** Slide expediter toward pipe and route cable through support base entry.

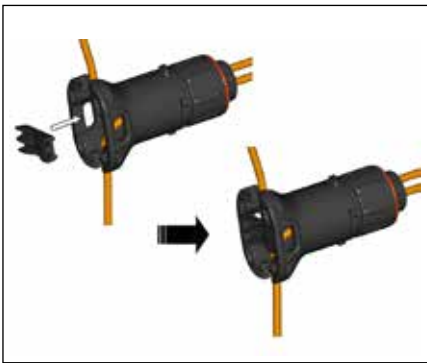

**4.** Insert banding guide into expediter and snap into place.

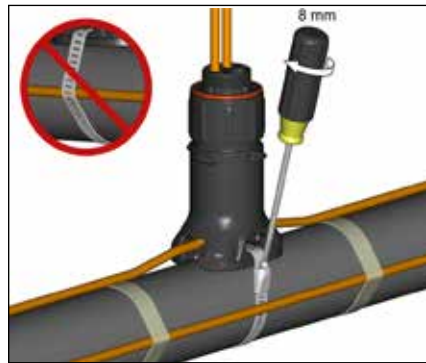

**5.** Mount expediter to pipe using pipe band. Do not band over cable.

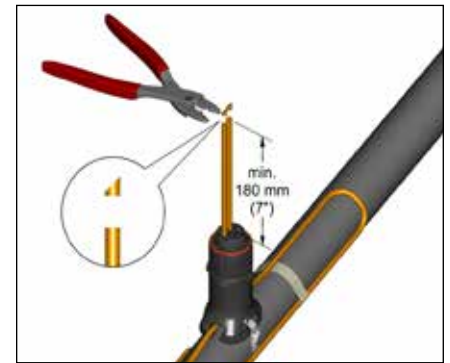

**6.** Cut off end of cable.

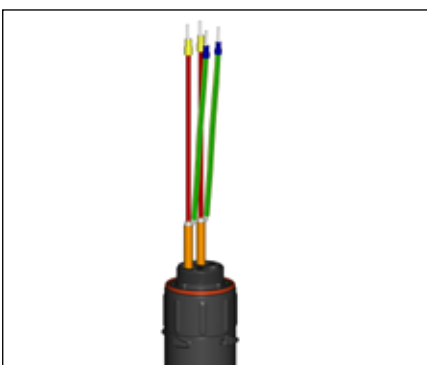

**7.** Terminate cable with appropriate PETK termination kit. Refer to PETK installation instructions.

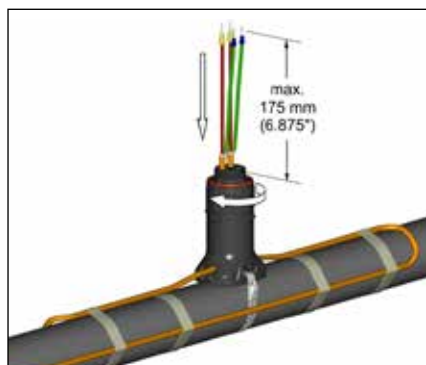

**8.** Push excess cable back through expediter. Tighten cap securely. Tape cable expansion loop to pipe.

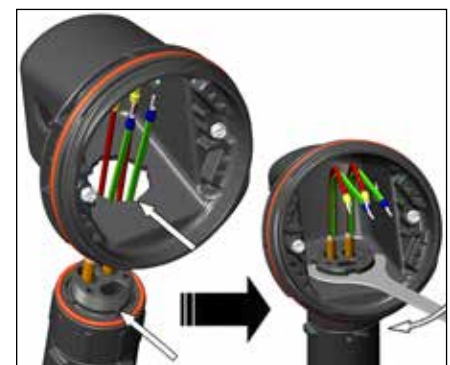

**9.** Mount junction box base on expediter. Make sure to align slots to properly orient junction box base. Tighten nut with Terminator-LN-Tool. If mounting horizontally, threaded gland holes must face downward.



**10.** Remove M25 dust cap. Install M25 power gland (order separately) and M25 blind plug. For in-line splice, T-splice, or end termination, install additional M25 blind plug (order M25-B-EXE separately) instead of M25 power gland.

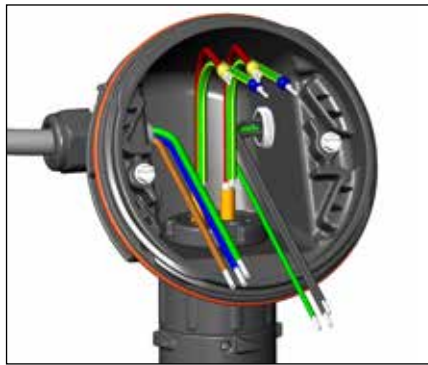

**11.** Install power cable.



**12.** Install terminal block and complete system wiring. Terminal set screws shall be tightened to a torque value of 1.4 Nm (12.4 lb-in). See below for wiring details.

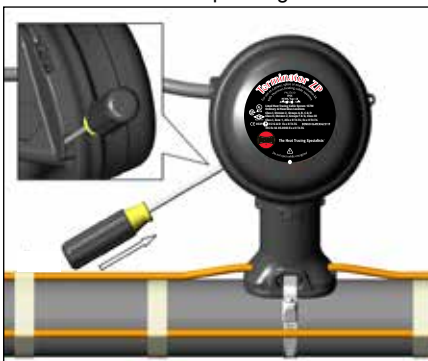

**13.** Install junction box lid and twist hand tight. Insert screwdriver into ratchet slots located on side of junction box base.

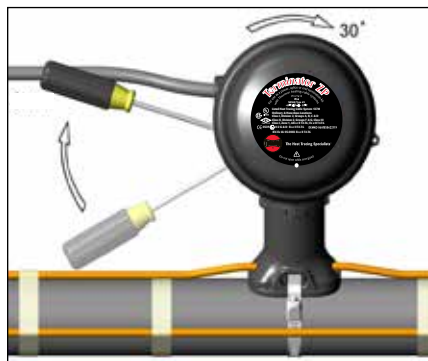

**14.** Use screwdriver to ratchet on junction box lid. Lid will rotate 30 degrees. To remove lid, repeat steps 13 and 14 but in the opposite direction.

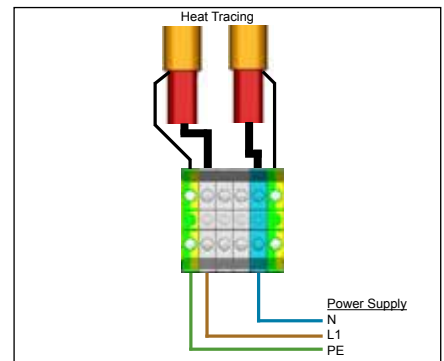

Wiring Details: Single Phase Circuit

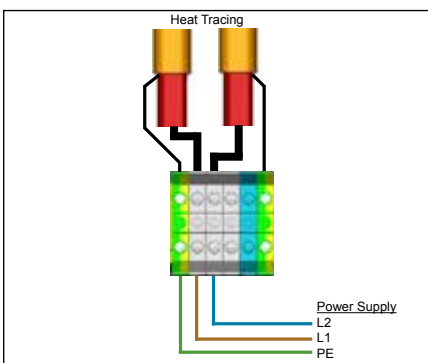

Wiring Details: Phase - Phase Circuit

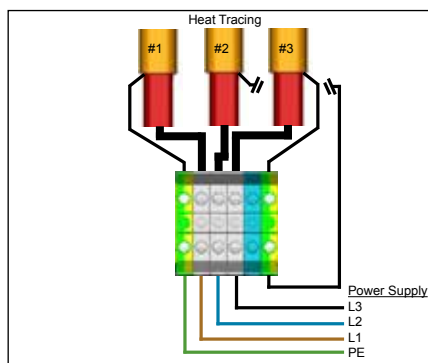

Wiring Details: 3-Phase Circuit (Power Side)

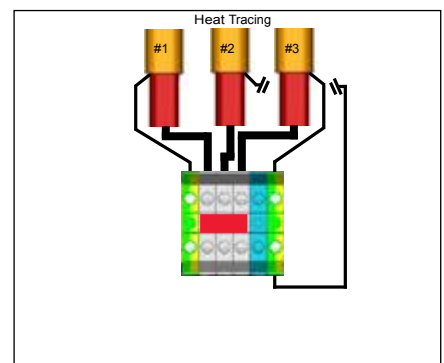

Wiring Details: 3-Phase Circuit (End or "Star" Side)

**Note:** Install separately supplied bridge on terminal L1, L2 and L3.



**THERMON . . . The Heat Tracing Specialists®**  
www.thermon.com

ISO 9001  
REGISTERED

**tce** Thermal Controls  
and Electronics

TC-E B.V.  
Nieuwland Parc 314c  
2952 DD Alblasterdam  
The Netherlands

+31 (0) 183 20 10 88  
sales@tc-e.nl  
www.tc-e.nl - www.heattrace.eu  
**Authorized Thermon distributor**